

Directional and flow control valves “COMNICA”

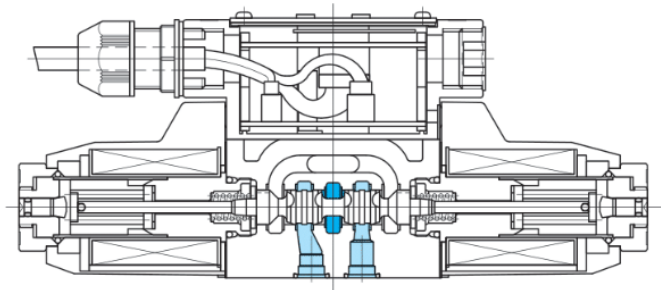
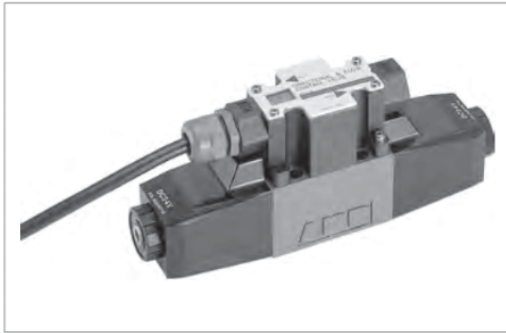

- COMINCA valves offer independent setting for acceleration and deceleration which is indispensable for shockless operation. High speed positioning which is difficult with conventional shockless valves and adjustable speed setting is possible.
- Onboard microprocessor allows setting of required parameters without valve to valve variation. Push button operation while monitoring the integrated digital indicator enables simple, repeatable setting and adjustment. Handheld setting device also available for same setting operation as valve mounted type.

- Compact, space-saving design with same configuration and robust construction as standard solenoid valves. Ease-of-use design facilitates operation as well as installation and maintenance with features such as manual override pins (for operation confirmation of deenergized valve), and reduced wiring.
- Can be connected to general purpose relays, PLCs, etc., like standard solenoid valves.

Model Code

The model notation format has also changed from the former to the new design.

COM-3 and COM-5 Series

	(Example notation)					
Active Design	COM - 3 - 3 3 C - 2 0 - CH - 1 1					
	(1)	(2)	(3)	(4)	(5)	(9)
	↓	↓	↓	↓	↓	↓
New Design	COM - 3 - 3 3 C - 2 0 - PHCC 1 - 3 0					
					(6)	(7) (8)

COM-52, COM-7 and COM-8 Series

	(Example notation)										
Active Design	COM - 7 - 3 1 C - 1 3 0 - CH - C - E - T - 1 0										
	(1)	(2)	(3)	(4)	(5)	(6)	(7)	(9)	(11)		
	↓	↓	↓	↓	↓	↓	↓	↓	↓		
New Design	COM - 7 - 3 1 C - 1 3 0 - E - T - PHCC 1 - 3 0										
						(8)	(10)				

- 1 Hydraulic fluid
Omit: mineral oil
F11: Water-glycol based fluid
- 2 COMNICA valve
- 3 Mounting dimensions
3: ISO 4401-03
5: ISO 4401-05
52: ISO 4401-05
7: ISO 4401-07
8: ISO 4401-08
- 4 Spool type
Refer to "Spool type".
- 5 P: Conduit box type : Notation changed from "CH/SH/AN" to "P".
- 6 H: 24-VDC power supply : Notation changed from the former design with no : (24-VDC) to "H".
- 7 With connector : "CC": CH type, "CA": AN type
- 8 Wiring lengths : Indicates 1, 2, 3, or 5-m length. (CC and CA types are 1 m only)
- 9 Design no. : Changed from 11 (COM-3) and 10 (COM-5) to 30.

Specifications

Model Code		COM-3	COM-5	COM-52	COM-7	COM-8
Rated Pressure	MPa	24.5	20.6	24.5		
Allowable Tank Port Back Pressure	MPa	13.7		Internal drain: 13.7		
				External drain: 24.5		
Max. control flow	L/min	30* ¹	70* ¹	80* ²	130* ²	250* ²
Min. control flow	L/min	0.5* ¹	1.5* ¹	2* ²	3* ²	5* ²
Pilot pressure	MPa	—	—	More than 2 MPa		
Hysteresis		Omitted: less than 7%, F11: less than 14%				
Repeatability		Less than 1% of max. flow				
Flow setting		Solenoid a, b 100 divisions each				
Min. working time	ms	50* ³	100* ³	70* ³		
Acceleration-deceleration time setting		0 to 9.9s (0.1s unit)/ 0 to 9.99s (0.01s unit) switchable				
Ambient temperature	°C	0~60				
Fluid temperature	°C	7~60				
Fluid viscosity	mm ² /s	20~300				
Vibration resistance		45 m/s ² (JIS D1601)				
Shock resistance		300 m/s ² (JIS C 0041)				
Waterproof, dustproof		IP54 (control SH, CH, AN) IP65 (wiring U, KU)				
Supply voltage * ⁴		DC 21.6~28 V				
Max. power consumption * ⁴		40 W (DC 24 V, 1.67 A)				
Input-output signals * ⁴		See table below				
Weight	kg	2.5	6.5	9	12	20

Note:

*1 When supply pressure is 6.9 MPa

*2 When valve differential pressure is 1 MPa

*3 During 0←→100% operation

*4 When a control function is provided

Control Function Note: The new '30' design integrates all previously separate control functions below into a single controller.

SH Type (Shockless)

Simple shockless and speed control by selecting A or B direction with contact signal of PLC, etc. In addition easy position control can be achieved by using the HALT function.

CH Type (3 Channel Setting)

Enables selection of three flows - high, medium, low speeds - for A, B direction and independent setting of acceleration, deceleration between the three flows.

AN Type (Analog Input)

Speed (flow) setting in real time with analog voltage. Acceleration, deceleration time setting possible.

Input-Output Signals

Control Function	Connection System	Contact Inputs	Analog Inputs	Contact Outputs
SH type	Omitted C type	3 contacts, internal common and sink wiring supported	—	—
	RC type	3 contacts, external common (bidirectional photo-coupler insulation), sink wiring/source wiring supported		
CH type	—	7 contacts, external common (bidirectional photo-coupler insulation), sink wiring/source wiring supported	—	1 contact, external common (bidirectional photo-coupler insulation)
AN type	Omitted C type	1 contact, internal common and sink wiring supported	1 contact, DC 0V to ±10V (command 0V and power 0V voltages connected internally)	—
	RC type	1 contact, external common (bidirectional photo-coupler insulation)		

• Contact point input ON: input common ⇔ voltage between contact point input, DC 15 V to 35 V

• Contact point input OFF: input common ⇔ voltage between contact point input, DC 0 V to 3 V

• Contact point output: max. load current 50 mA

* All contact signal except for AN type DC±10 V signal.

* The analog input voltage of the AN type is the voltage referenced to the command 0V. Furthermore, the command 0V voltage is connected internally to the power 0 V voltage.

Spool Types

Spool Center Position		Functional Symbol		
		COM-3/5	COM-52/7/8	
2		Closed center		
33		A-B-T connected w/restrictors		

Characteristics Curve (viscosity 20 mm²/s, specific gravity 0.87) (typical examples)

COM-3 (characteristics applicable in the case of the COM-3-2C-30-AN-11)

Input Voltage - Flow Characteristics

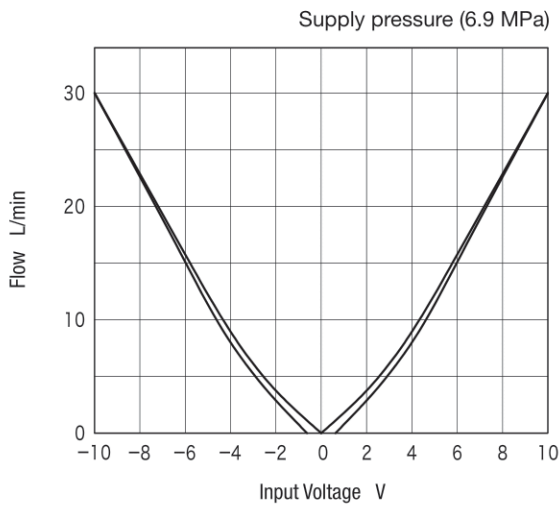

Supply Pressure - Flow Characteristics

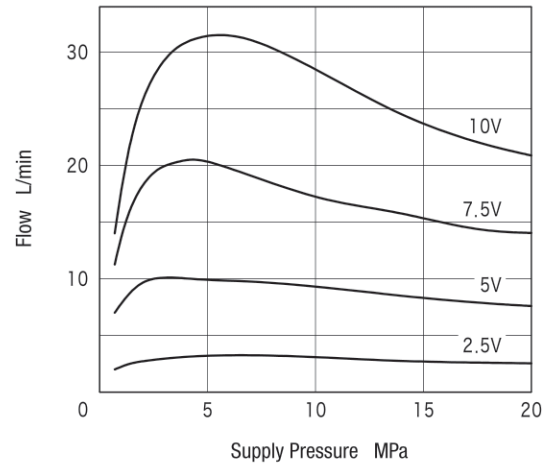

COM-5 (characteristics applicable in the case of the COM-5-2C-70-AN-10)

Input Voltage - Flow Characteristics

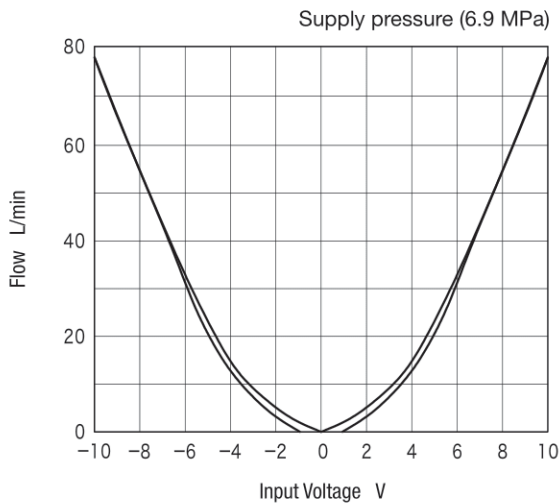

Supply Pressure - Flow Characteristics

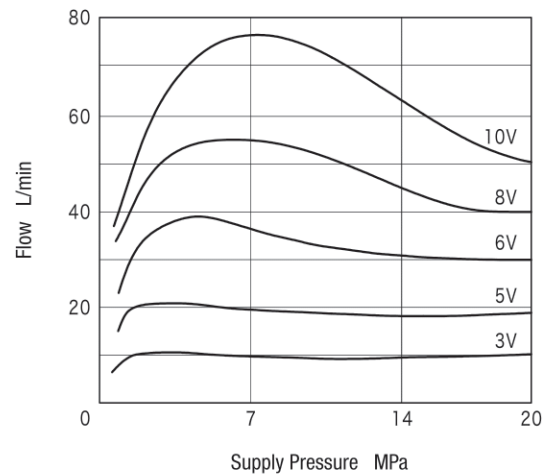

COM-52 (characteristics applicable in the case of the COM-52-2C-80-AN-10)

Input Voltage - Flow Characteristics

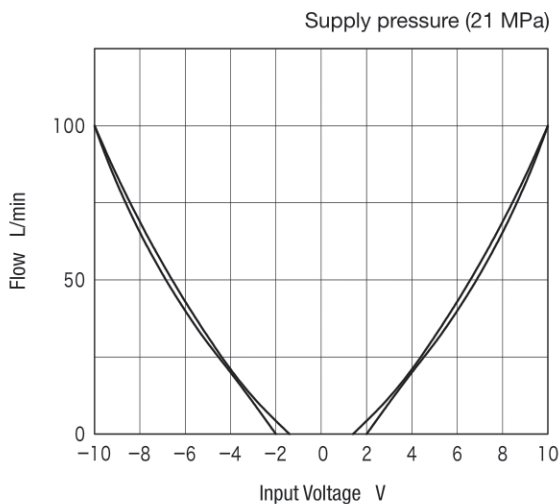

Supply Pressure - Flow Characteristics

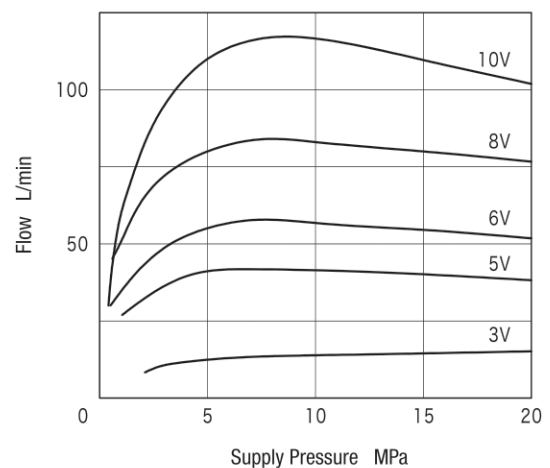

Characteristics Curve (viscosity 20 mm²/s, specific gravity 0.87) (typical examples)

COM-7 (characteristics applicable in the case of the COM-7-2C-130-AN-10)

Input Voltage - Flow Characteristics

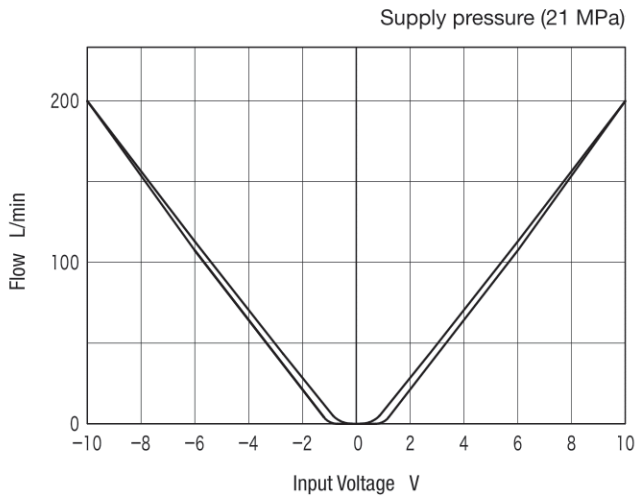

Supply Pressure - Flow Characteristics

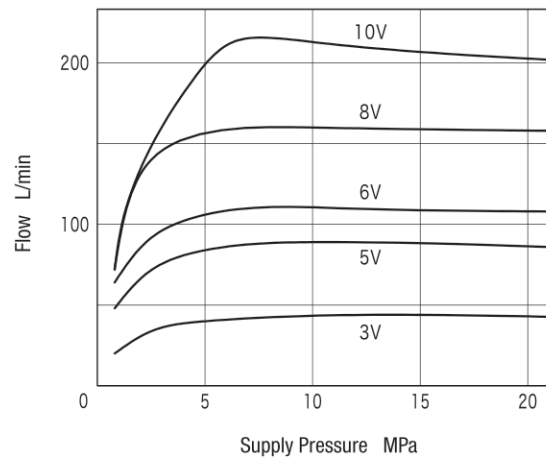

COM-8 (characteristics applicable in the case of the COM-3-2C-250-AN-10)

Input Voltage - Flow Characteristics

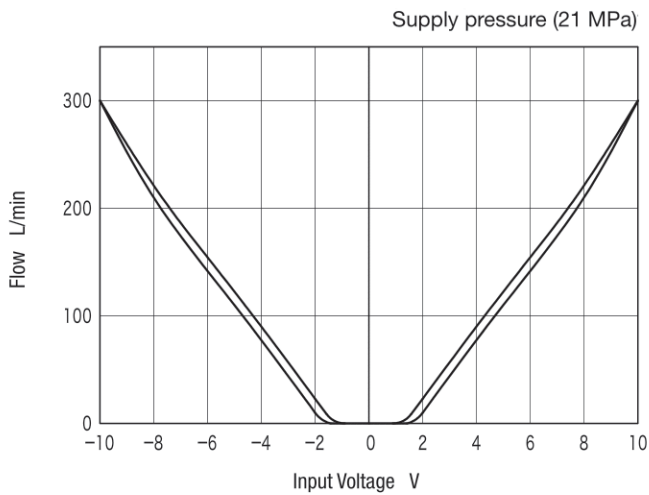

Supply Pressure - Flow Characteristics

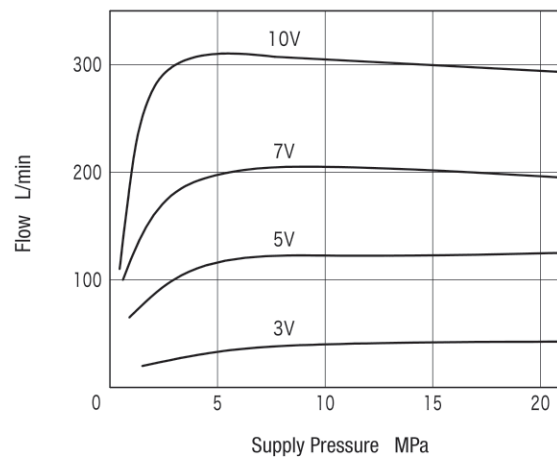

1. Mounting orientation
Mount valves so spool axis is horizontal.
2. T port
Prevent pressure surges above 13.7 MPa (24.5 MPa for external drain) from being generated in T port. Ensure that valve is always filled with oil.
3. Signal line
Ends of signal wires not used should be insulated and short circuits should be prevented.
4. Wiring specifications
When using extended lead wires for COMNICA valves, insure that cables are heat and oil resistant and of proper size as described below.
 - Power supply (24V or 0V)
AWG18 or above 0.75 mm²
 - Contact point signal or analog input
AWG22 or above 0.3 mm²
5. Contact point input-output current
When contact signal is input, the following currents flow to the contact points of the PLC, relay, etc. Care should be paid to the current limitations of external devices.

Setting point current (A) \approx (contact point input voltage - 1) / 15000

Operation output (CH type only) max. load current is 50 mA and care should be paid to the load on the PLC, relay, etc. Especially when connecting directly to LED, etc., serially connect resistance to operational output + or operational output -, and limit current.

Minimum applicable load (Ω) \approx (load voltage - 1.2) / 0.05

6. Manual operation
For manual switching, push the manual override pin. Be aware that actuation force increases with higher back pressure.
7. Waterproof, dustproof
Water and dust protection class is IP54. Separate protection should be implemented for jets from nozzles, etc. In order to maintain water and dust resistance, nameplate and packing should be tightened with the tap pins after adjustment of settings.
Tightening torque: 0.34 to 0.53 N·m
8. Chattering may arise when these valves are used in combination with the pilot check valves. In cases like this, use the external drain type of pilot check valves.
9. EMI (electro-magnetic interference)
Valve control flow may vary with changes in the magnetic field. As shown in the examples below, when flow is controlled by solenoid "a" and a nearby solenoid valve is energized, controlled flow of the COMNICA valve may increase or decrease as shown in the table. Therefore caution should be exercised when COMNICA valves are operated in proximity to solenoid valves.

Example 1: COM-3

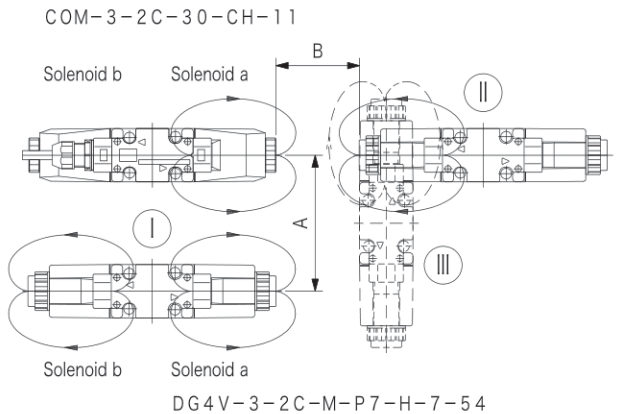

Flow Variation of COMNICA Valve When Solenoid Valve Switched at 1 L/min				
i) Valve position ①		ii) Valve position ② or ③		
Flow variation: L/min		Flow variation: L/min		
A mm	DG4V-3 Solenoid 'a' Energized	DG4V-3 Solenoid 'b' Energized	B mm	DG4V-3 Solenoid Energized
47	0.50	0	25	0.10
57	0.20	0	50	0.05
97	0.10	0		
147	0.02	0		

Example 2: COM-5

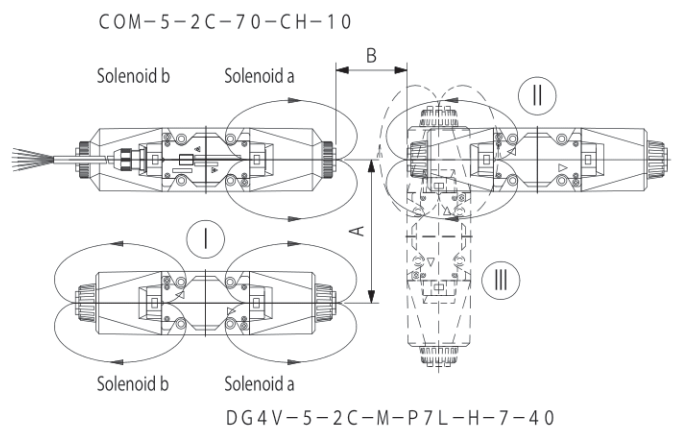

Flow Variation of COMNICA Valve When Solenoid Valve Switched at 5 L/min				
i) Valve position ①		ii) Valve position ② or ③		
Flow variation: L/min		Flow variation: L/min		
A mm	DG4V-5 Solenoid 'a' Energized	DG4V-5 Solenoid 'b' Energized	B mm	DG4V-5 Solenoid Energized
70	1.40	0	25	0.30
80	0.65	0	50	0.10
120	0.30	0		
170	0.10	0		

Notes regarding the above examples.

- Values may differ according to the orientation of electromagnetic fields and the electrical wiring shown in the illustration.
- Solenoid valves placed in proximity in positions other than those illustrated may also increase/decrease COMNICA valve controlled flows.
- Similar interference may occur with COM-7/8. Consult Tokyo Keiki for details.

COM-3

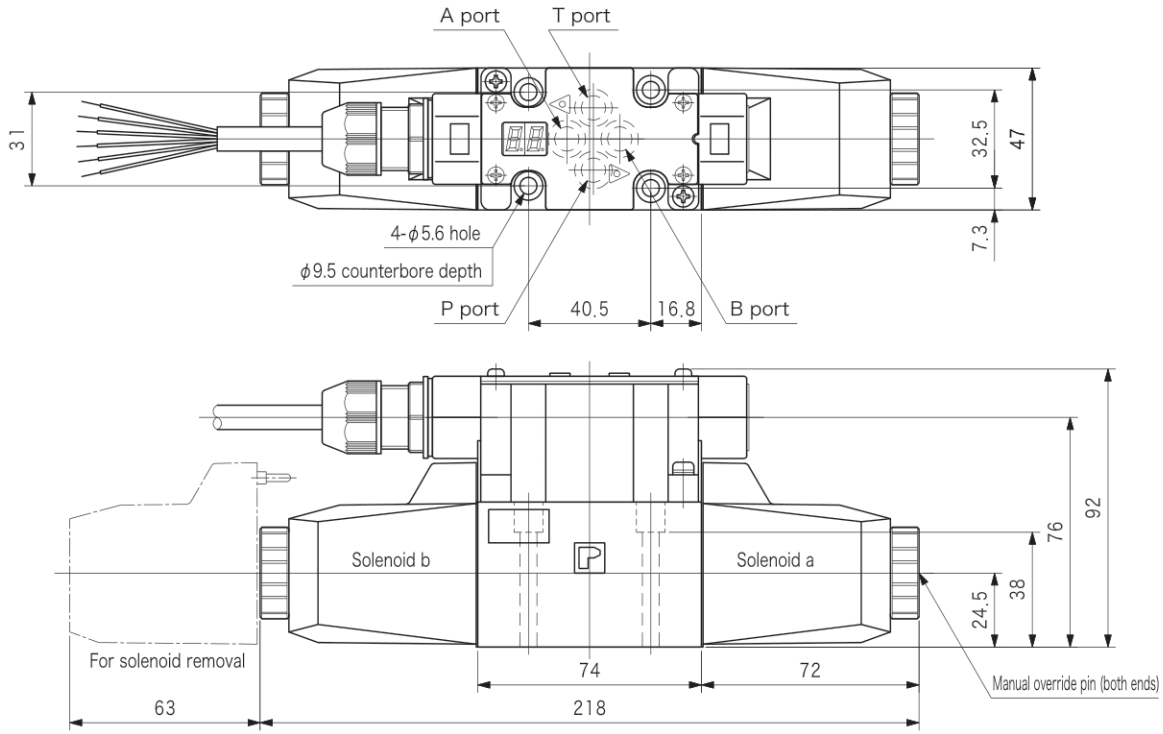

Note: When an adapter plug is provided, refer to page E16-10 for the connection area.

COM-3-KU

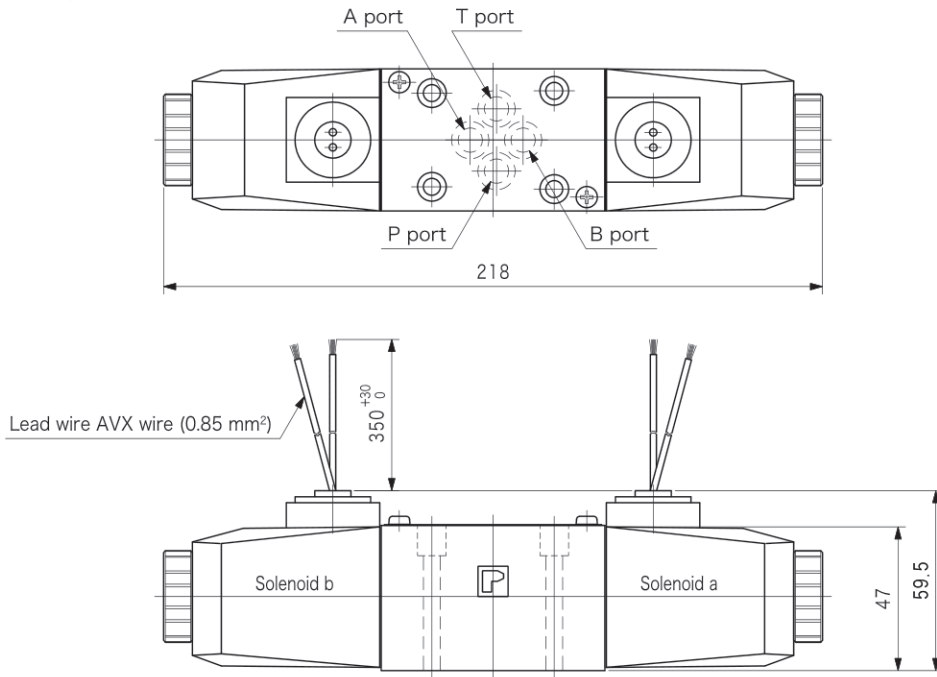

● Mounting dimensions

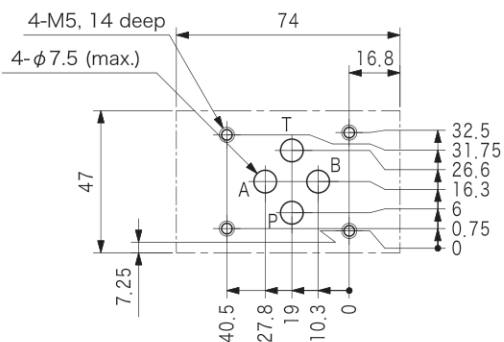

Dimensions

COM-3-U

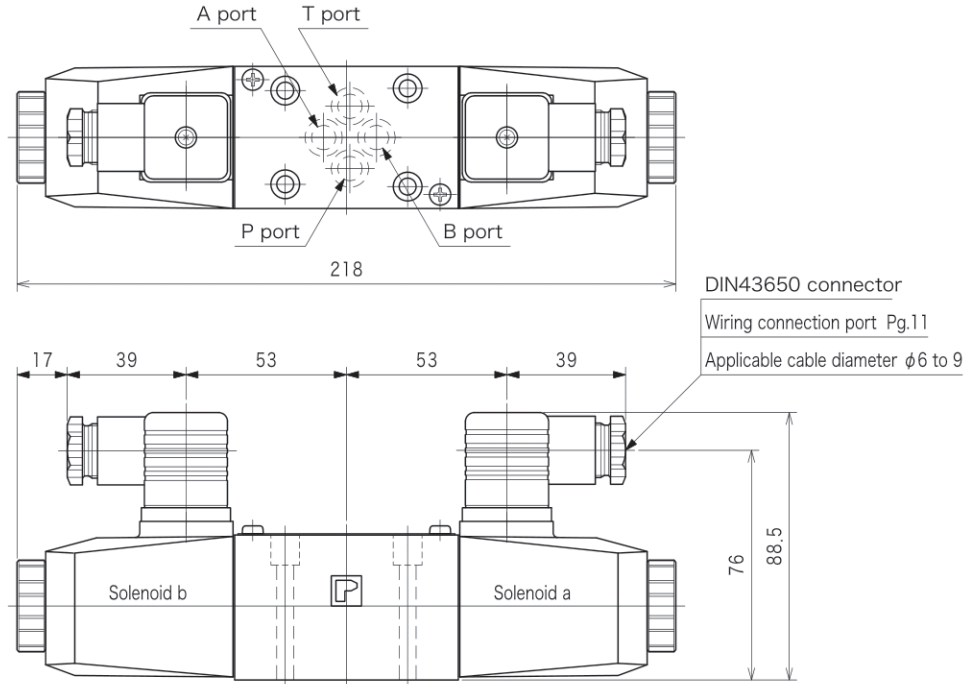

COM-5

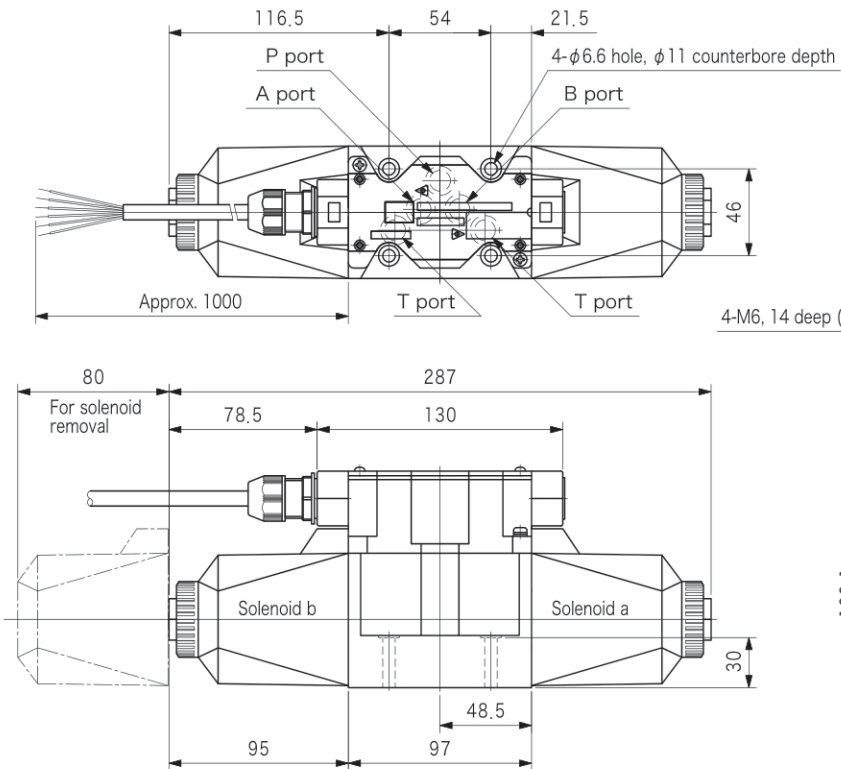

● Mounting dimensions

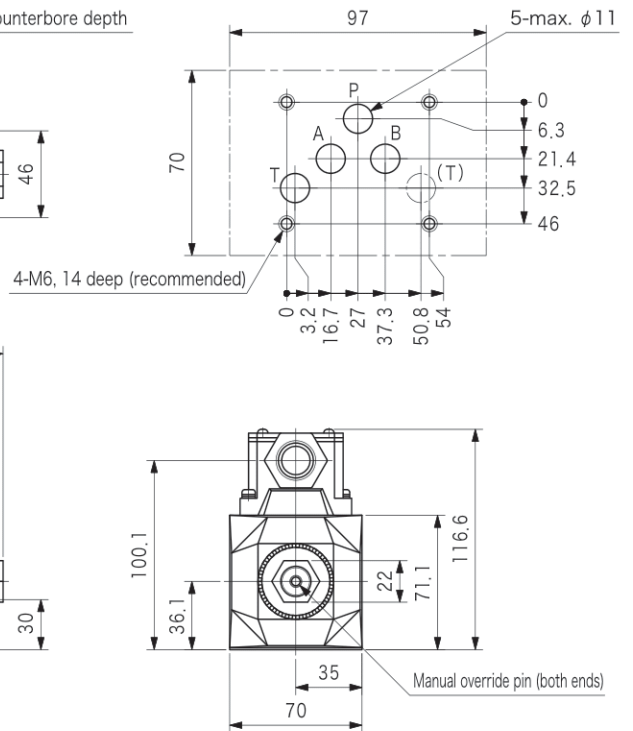

Note: When an adapter plug is provided, refer to page E16-10 for the connection area.

Dimensions

COM-5-KU

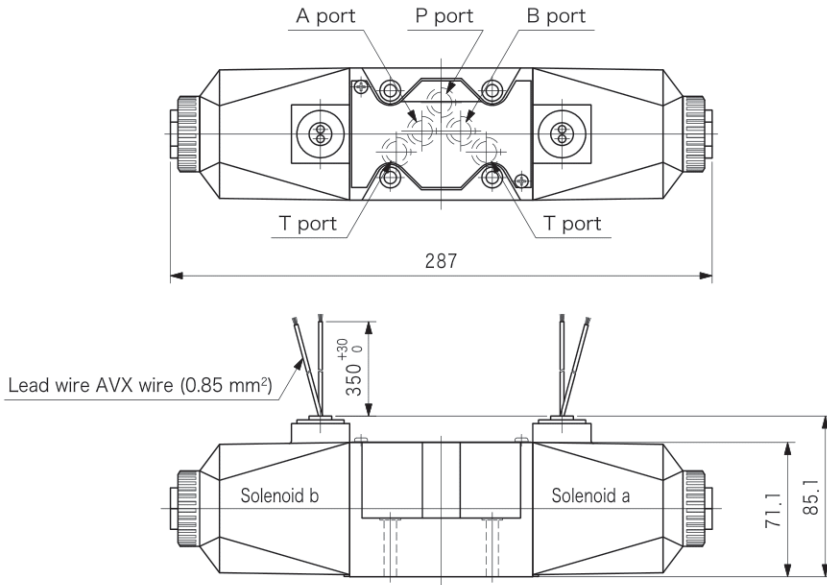

COM-5 2

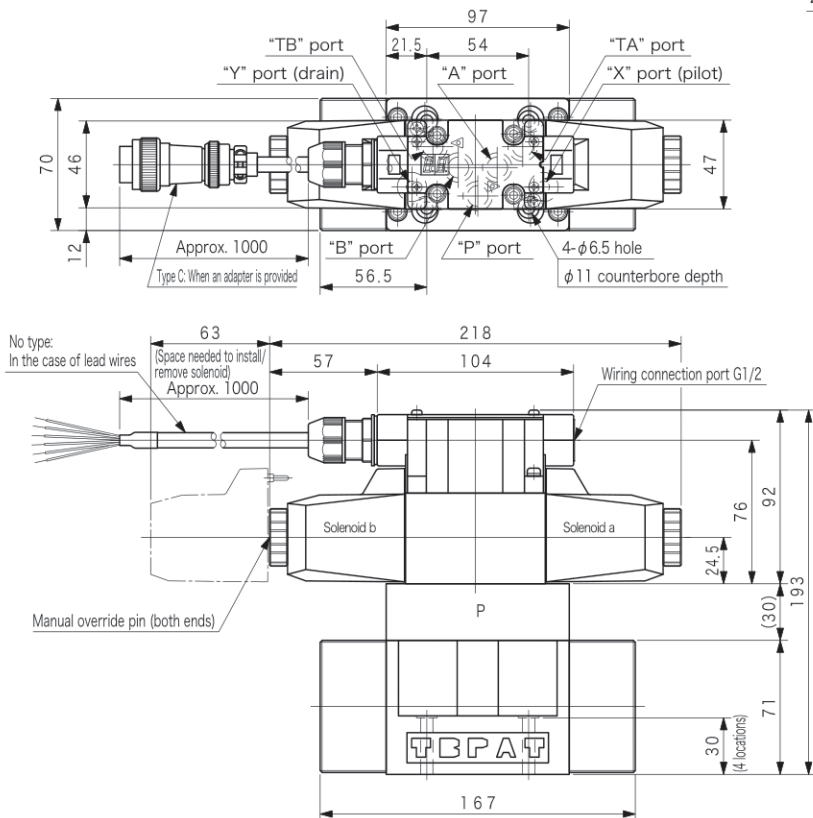

● Mounting dimensions

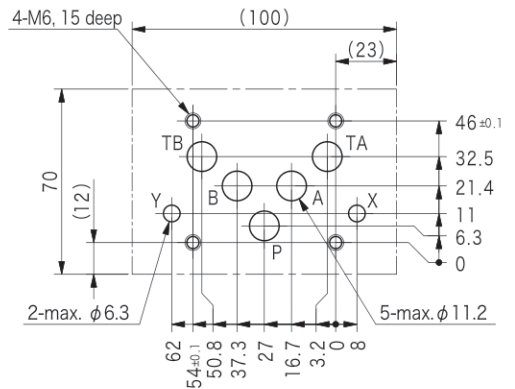

Note:

- When an adapter plug is provided, refer to page E16-10 for the connection area.
- Consult Tokyo Keiki for the outline drawings of the U and KU types.

Dimensions

COM-7

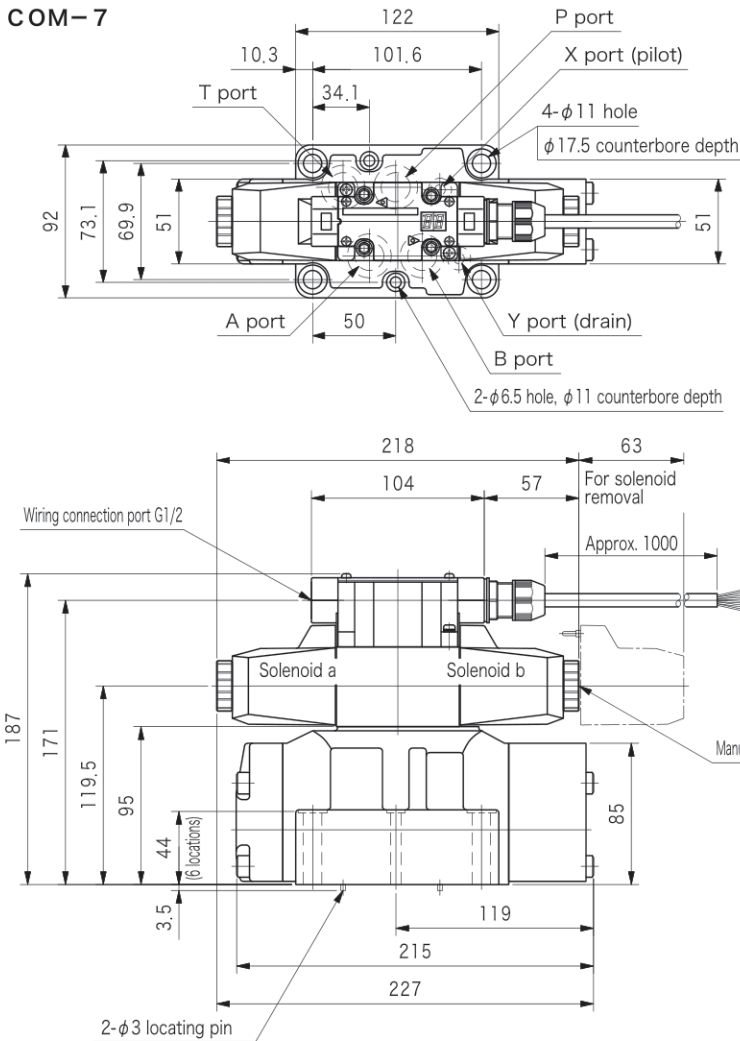

● Mounting dimensions

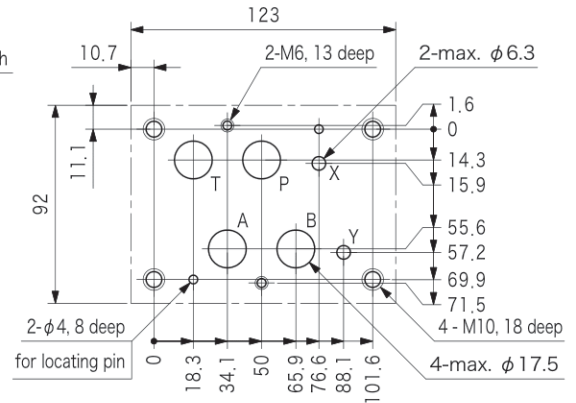

Note:

- When an adapter plug is provided, refer to page E16-10 for the connection area.
- Consult Tokyo Keiki for the outline drawings of the U and KU types.

COM-8

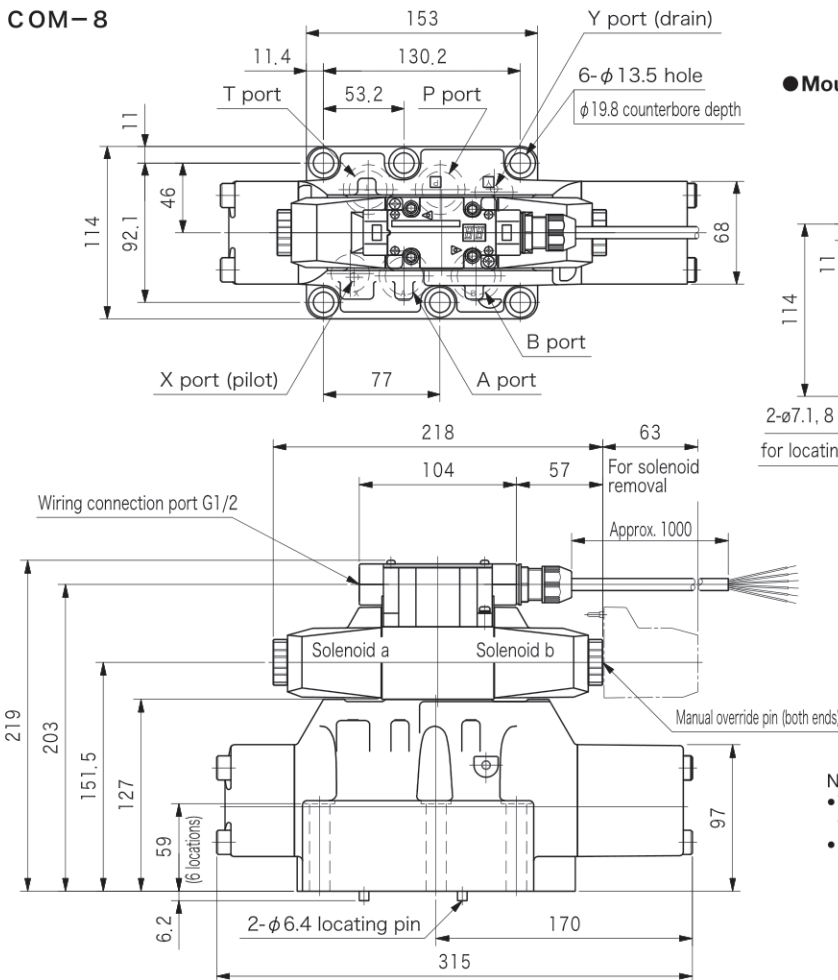

● Mounting dimensions

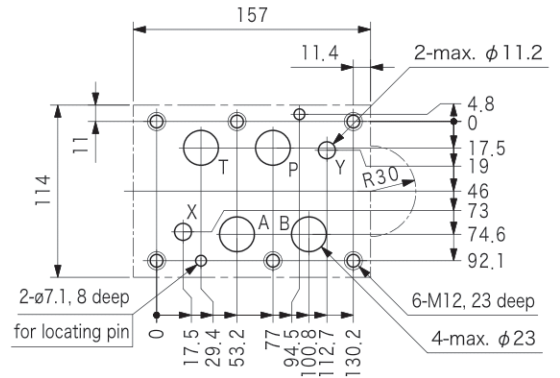

Note:

- When an adapter plug is provided, refer to page E16-10 for the connection area.
- Consult Tokyo Keiki for the outline drawings of the U and KU types.

Dimensions

COM-3/52/7/8-C

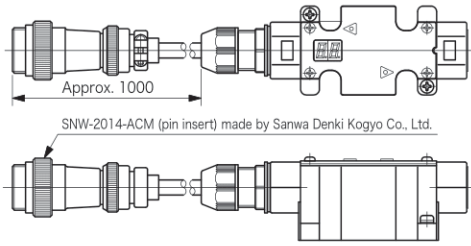

COM-3/52/7/8-RC

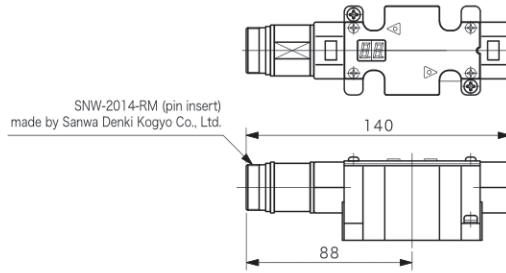

COM-5-C

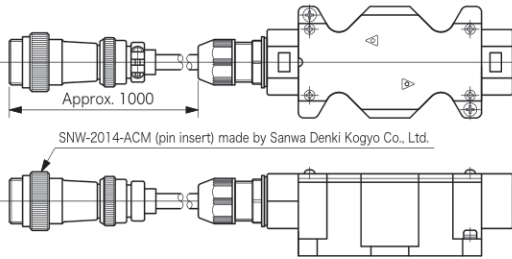

COM-5-RC

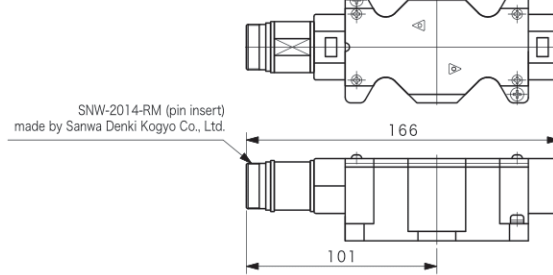

Note:

- The inter-fitting position of the -RC type differs depending on the individual valve. Do not use the L-type plug.
- A contact input common pin is provided on the SH type and AN type of the -RC type.

Special Harness

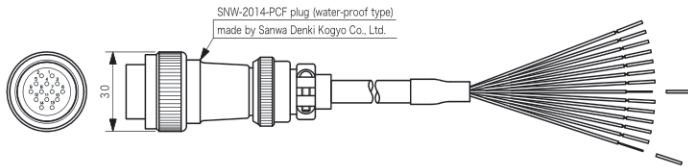

- This harness is connected to the -RC type.
- An input common pin is available and, therefore, both sink wiring and source wiring are supported.

Note:

- When used for the -C type, the contact input common pin (orange-black) cannot be used. (+24V common fixed)
- The power 0V and command 0V voltages of the AN type are shorted internally.
- The inter-fitting position of the plug differs depending on the individual valve.

COM-H-CH-RC-1000-10

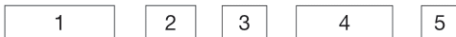

- 1 Harness specially designed for COM series
- 2 CH: For CH type
SH: For SH type
AN: For AN type
- 3 Specially designed with receptacle (RC type)
- 4 Harness length (unit: mm)
1000, 2000, 3000, 4000, 5000
- 5 Design no.

Receptacle Pin No.	Wire Color	CH Type	SH Type	AN Type
1	Red	Power DC24V	Power DC24V	Power DC24V
2	Black	Power 0V	Power 0V	Power 0V*
3	White - Red ·	1A input	A input	Command input
4	White - Black ·	2A input		
5	Yellow - Red ·	3A input		
6	Yellow - Black ·	1B input	B input	Command 0V*
7	Pink - Red ·	2B input		
8	Pink - Black ·	3B input		
9	Orange - Red ·	Emergency stop input	Stop input	Emergency stop input
10	Orange - Black ·	Contact input common	Contact input common	Contact input common
11	Grey - Red ·	Operation enable output +		
12	Grey - Black ·	Operation enable output -		
13	Orange - Red · ·	Chassis ground	Chassis ground	Chassis ground
14	Grey	Shield	Shield	Shield

* The command 0V and power 0V voltages are shorted inside the valve.

Shockless (SH) Type

Operation

Two - high/low speed - flow levels, high/low speed arrival times, and low speed flow hold time can be independently set for solenoids "a" and "b." Shockless operation and speed control (flow control) can be easily obtained by selecting the A (solenoid 'a') or B (solenoid 'b') direction with the contact point signals of the PLC. Also positioning control can be obtained by using the stop signal (HALT). (When the energize signal to the solenoid is cut, mode automatically switches to low speed.)

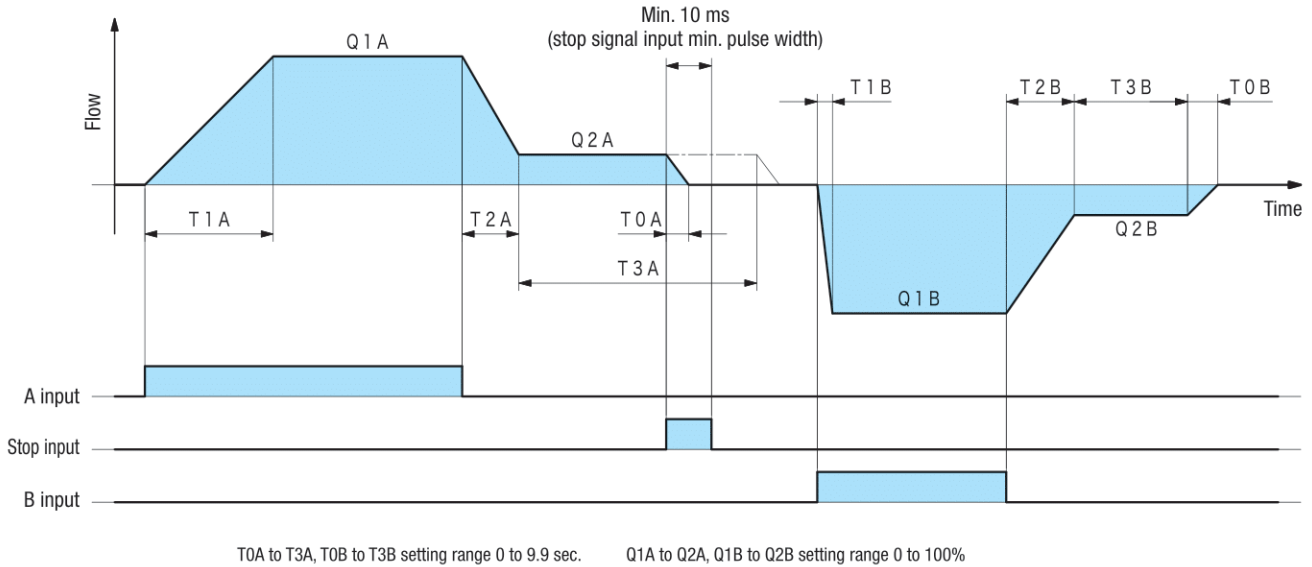

If stop (HALT) signal is input, COMNICA valve will stop according to deceleration time T0A or T0B setting.

Electrical Wiring Examples

1-meter harness type

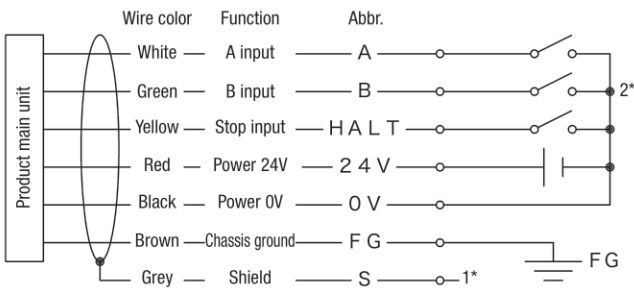

*1 When using shielded cables, connect shield cable to FG (ground earth) or 0V.

*2 Only the sink connection is supported.

1-meter harness type with connector

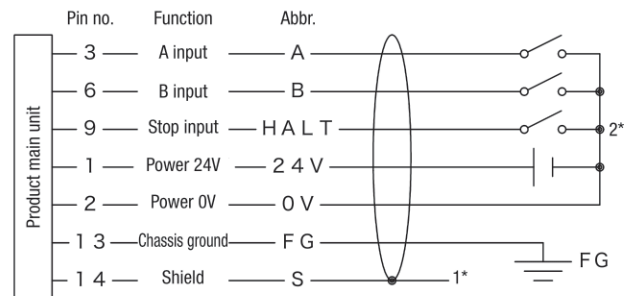

*1 When using shielded cables, connect shield cable to FG (ground earth) or 0V.

*2 Only the sink connection is supported.

Receptacle connector type

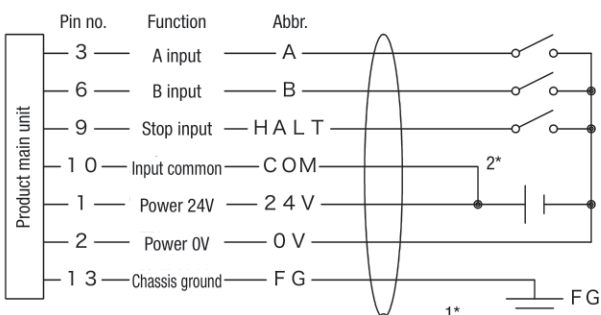

*1 When using shielded cables, connect shield cable to FG (ground earth) or 0V.

*2 Both the sink connection and source connection are supported.

3 Channel Setting (CH) Type

Operation

Three flow levels - high speed, medium speed, low speed - and arrival times for solenoids "a" and "b" can be independently set. Valve can be directly connected to PLC, general-purpose relays, proximity switches, etc., to provide simple management of shockless operation, speed control (flow control) and positioning.

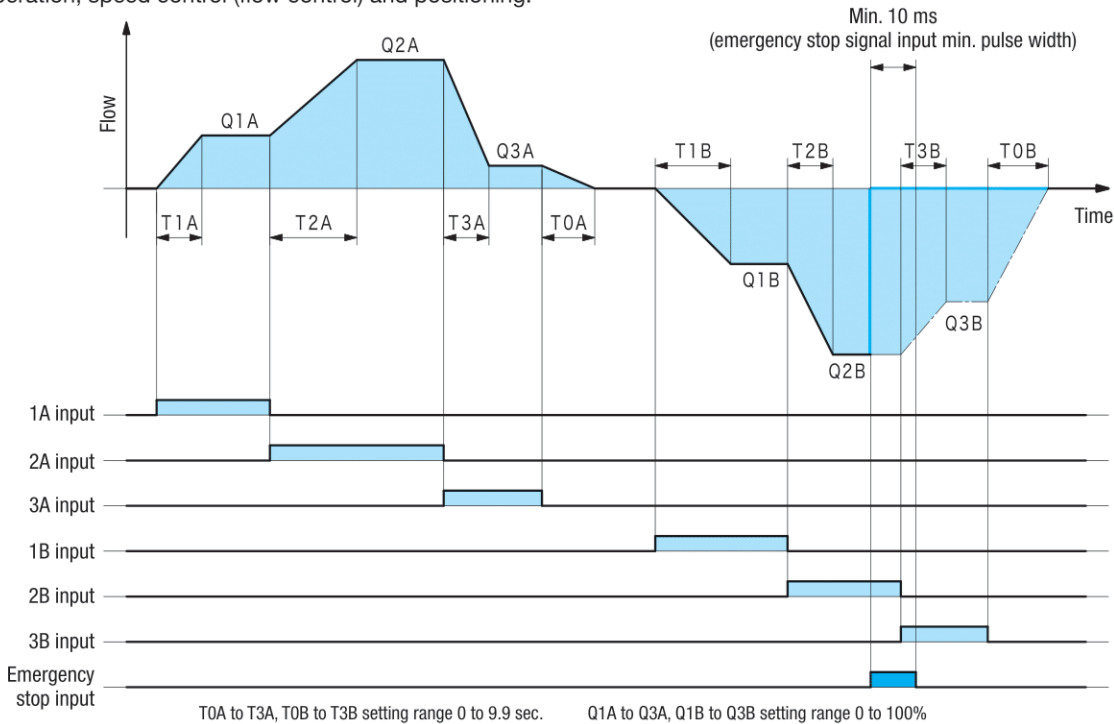

Input of emergency stop signal will immediately generate zero output from amp to valve regardless of whether there are other contact point input signals and valve returns to neutral position and zero flow. Time of valve return to neutral position will be the minimum time of the valve regardless of the T0A and T0B setting times.

Operational output signal will be ON (contact point closed) when controller is operating normally and OFF (contact point open) under abnormal conditions and during data setting. Operational condition can be viewed with the monitor.

Electrical Wiring Examples

1-meter harness type

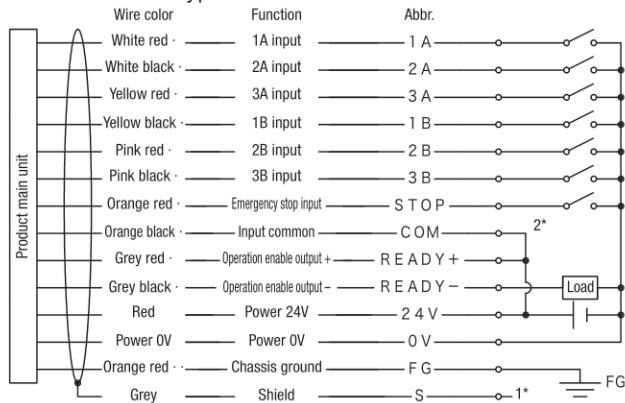

*1 When using shielded cables, connect shield cable to FG (ground earth) or 0V.

*2 Both the sink connection and source connection are supported.

1-meter harness type with connector

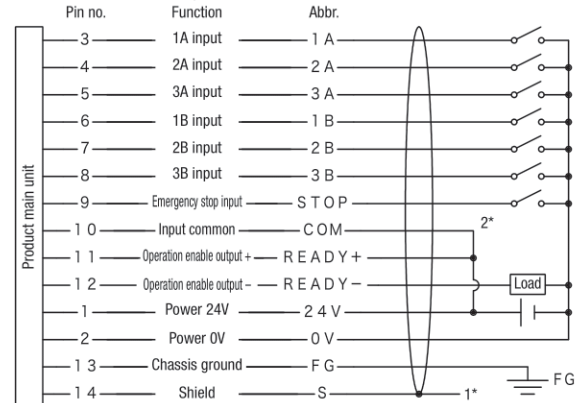

*1 When using shielded cables, connect shield cable to FG (ground earth) or 0V.

*2 Both the sink connection and source connection are supported.

Receptacle connector type

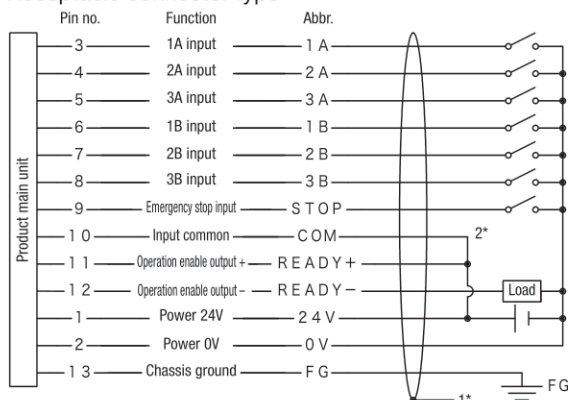

*1 When using shielded cables, connect shield cable to FG (ground earth) or 0V.

*2 Both the sink connection and source connection are supported.

Operation

Operation is based on direction of analog voltage polarity with absolute values specified for flow. By setting lag time in advance, ramping can be achieved in response to step input. Lag time is set by arrival time against max. flow. A direction ramp up time (TAU), ramp down time (TAD), B direction ramp up time (TBU) and ramp down time (TBD) can be set separately.

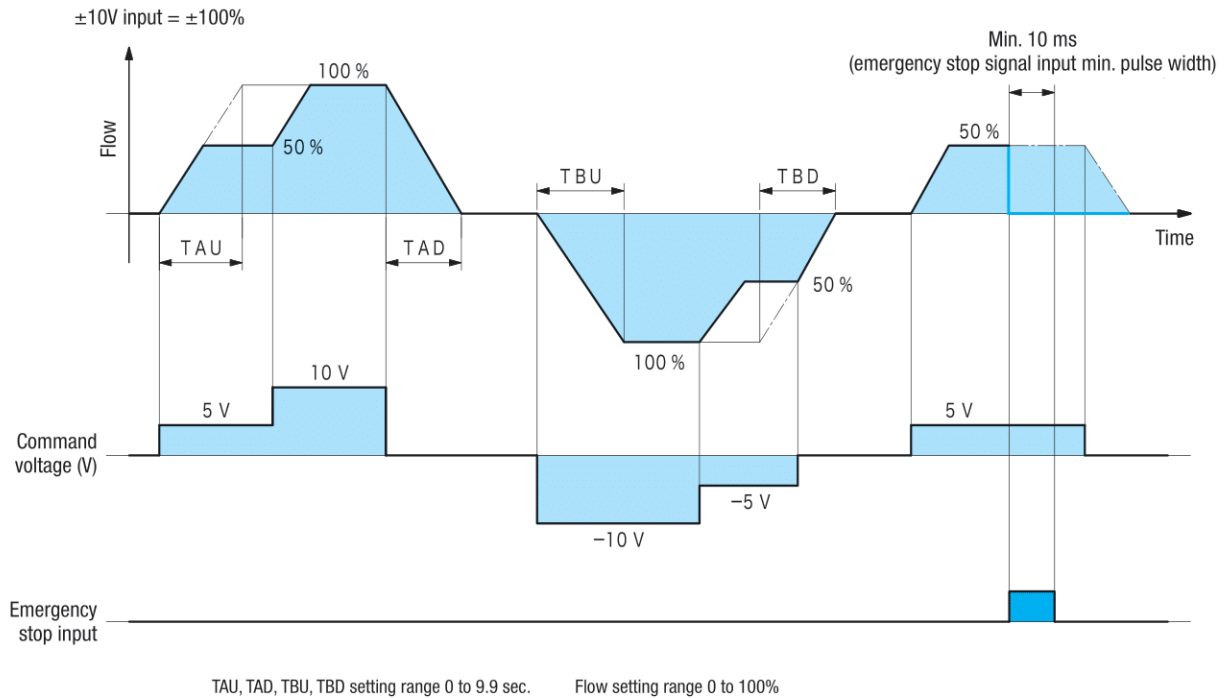

Input of emergency stop signal, will immediately generate zero output from amp to valve regardless of command voltage and valve returns to neutral position with zero flow. Time of valve return to neutral position will be the minimum time of the valve regardless of the TAD and TBD setting times.

Electrical Wiring Examples

1-meter harness type

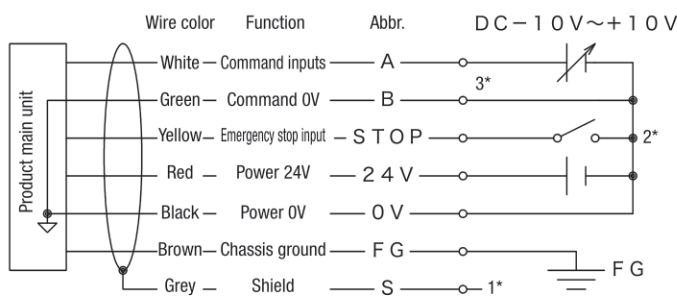

- *1 When using shielded cables, connect shield cable to FG (ground earth) or 0V.
- *2 Only the sink connection is supported.
- *3 The command 0V voltage is connected to the power 0V voltage inside the product main unit.

1-meter harness type with connector

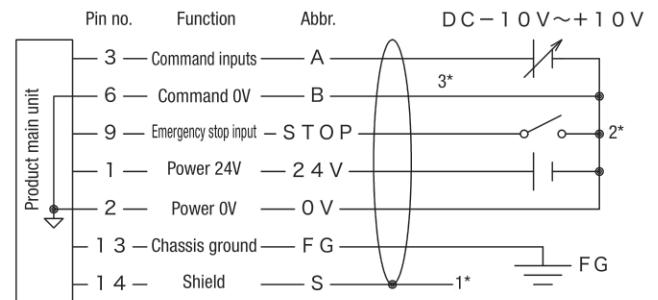

- *1 When using shielded cables, connect shield cable to FG (ground earth) or 0V.
- *2 Only the sink connection is supported.
- *3 The command 0V voltage is connected to the power 0V voltage inside the product main unit.

Receptacle connector type

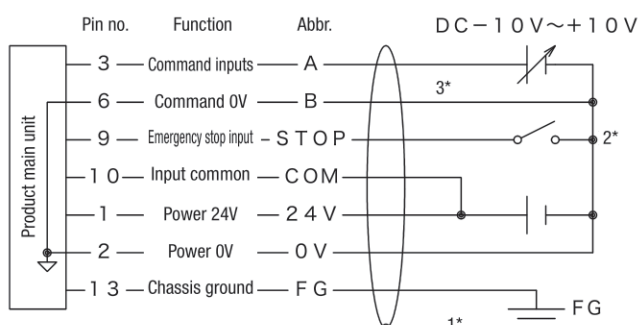

- *1 When using shielded cables, connect shield cable to FG (ground earth) or 0V.
- *2 Both the sink connection and source connection are supported.
- *3 The command 0V voltage is connected to the power 0V voltage inside the product main unit.

Controller Unit Nomenclature and Functions

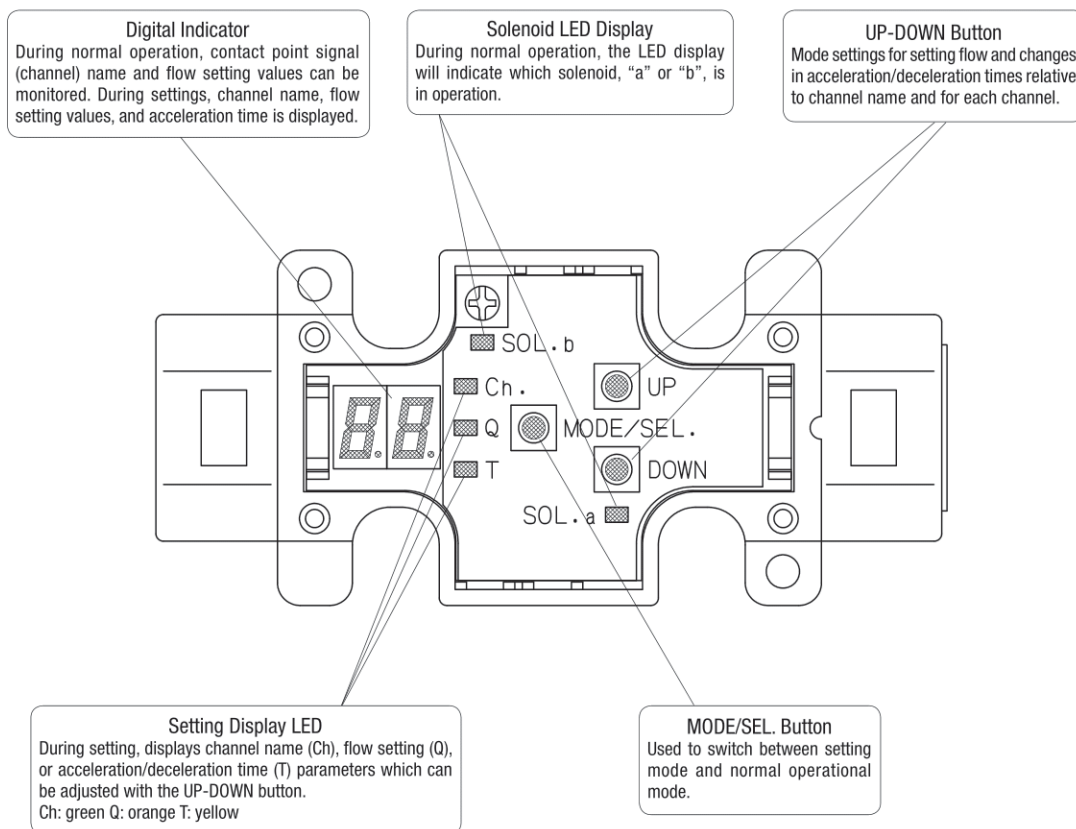

E 16-14 Directional Control Valves

Options

Handheld Setting Device

Model code: COH-1-10 (for all COMNICA valves)

- Handheld setting device allows easy data setting of COMNICA valves in difficult locations.
- Contact point signal name and flow setting values selected during operation can be monitored similar as with the valve display.
- COMNICA valve basic data can be copied to the handheld setting device and copied into other COMNICA valves enabling same settings for multiple valves.

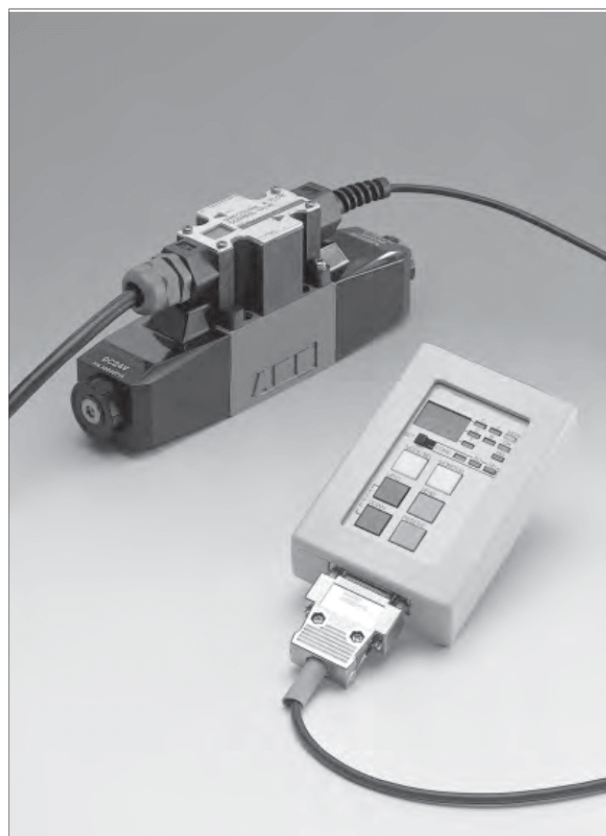
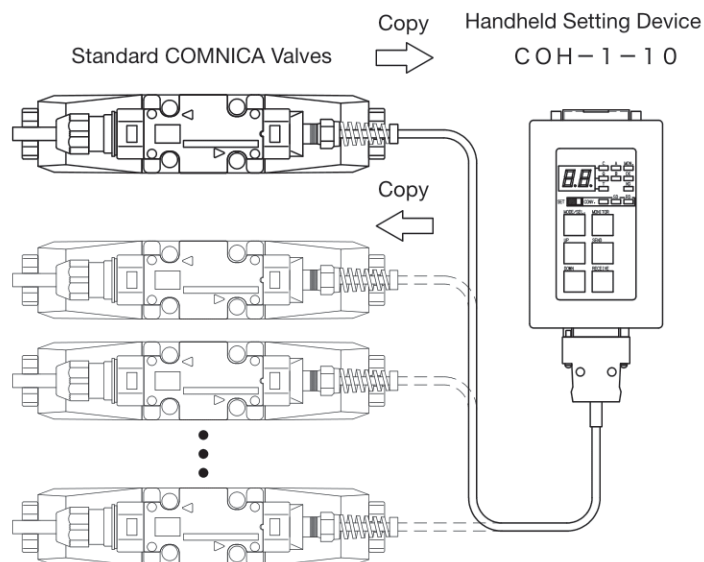

Options

○ These separate controllers are used to drive the U and KU types.
The control system, wiring and other characteristics are the same as for the installed controllers.

COM-AMP-3-CH-H-1 1

1 2 3 4 5

1 COMNICA valve separate controller

2 Compatible valves

- 3: For COM-3
- 5: For COM-5
- 52: For COM-52
- 7: For COM-7
- 8: For COM-8

3 Control

SH: Shockless

CH: 3 Channel setting

AN: Analog input

4 Supply voltage

H: DC24V

G: DC12V

5 Design no.

Model Code	COM-AMP-*-*-G-11	COM-AMP-*-*-H-11
Applicable solenoid coil	For DC12V	For DC24V
Power supply	Voltage DC10.8 to 14V Current 1.8A or higher	Voltage DC21.6 to 28V Current 1.8A or higher
Max. power consumption	22W	40W
Ambient temperature	0~60°C	
Relative humidity	40~70%	
Storage temperature	-10~60°C	
Vibration resistance	45m/s ² (JIS D 1601)	
Shock resistance	150m/s ² (JIS C 0041)	
Waterproof, dustproof	IP20	
Communication	Conforming to RS-422	
Wiring specifications	1-meter harness provided	
I/O	Electrical Wiring Examples	

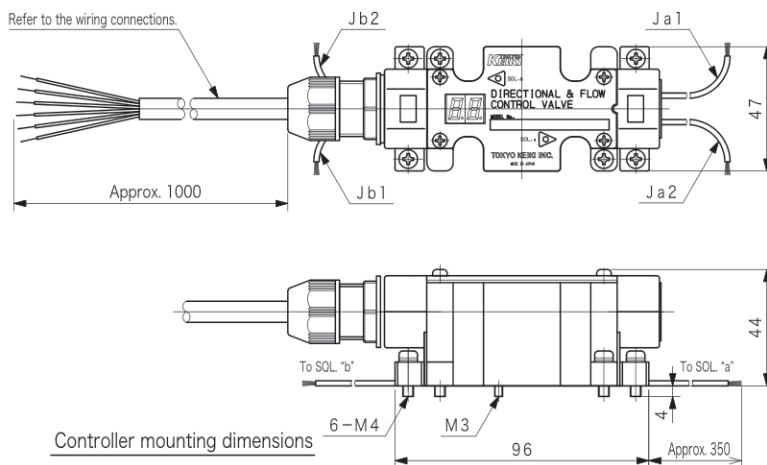

Controller mounting dimensions

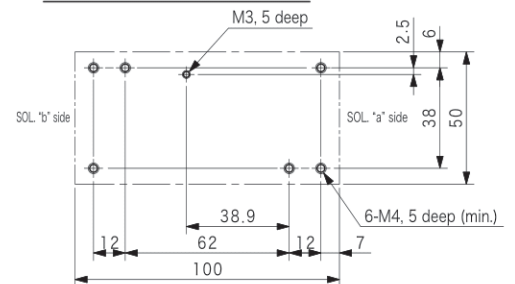

Method of connecting the wires between the controller and valve body

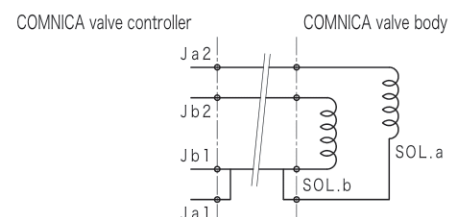

Mounting Bolts (JIS B 1176, Strength Class 12.9)

Valve Model	Hex Socket Bolts	Qty
COM-3	M5 × 50	4
COM-5, COM-52	M6 × 40	4
COM-7	M10 × 60	4
	M6 × 55	2
COM-8	M12 × 80	6

- Mounting bolts must be ordered separately.
- Tightening torque of mounting bolts
M5: 7 to 8 N·m
M6: 9 to 14 N·m
M10: 50 to 60 N·m
M12: 75 to 81 N·m

Subplate

COM-3/5

Valve Model	Subplate	Connection Port Dia. Rc	Porting
COM-3	DGMS-3-1E-10-T-JA-J	3/8	Side
	DGVM-3-10-T-JA-J		Rear
COM-5	DGSM-01X-10-JA-M	3/8	Rear
	DGSM-01Y-10-JA-M	1/2	

COM-7/8

Valve Model	Subplate	Connection Port Dia. Rc	
		P, T, A, B	X, Y
COM-7	DGSMV-04-10	1/2	1/4
	DGSMV-04X-10	3/4	
COM-8	DGSMV-06-10	3/4	1/4
	DGSMV-06X-10	1	

- A subplate is not available for the COM-52 model.
- Subplate must be ordered separately.
- See page R6-5 to R6-7 for dimensions.
- COM-3/5 mounting bolts must be ordered separately. COM-7/8 subplates are supplied with hex socket bolts for mounting valve.
- Max. working pressure is 21 MPa. For higher pressures, valve should be mounted on manifold block.

Construction

O-ring COM-3

No.	Part No.	Standard	Qty
2	008001917	JIS B 2401 1A-P21	2
4	008000217	JIS B 2401 1A-P4	4
7	007911429	AS568-114 (FKM, Hs90)	2
11	007901219	AS568-012 (NBR, Hs90)	4
14	007900817	AS568-008 (NBR, Hs70)	1

O-ring COM-5

No.	Part No.	Standard	Qty
2	007912117	AS568-121 (NBR, Hs70)	2
4	008000217	JIS B 2401 1A-P4	4
5	007902617	AS568-026 (NBR, Hs70)	2
7	007911729	AS568-117 (FKM, Hs90)	2
11	007901419	AS568-014 (NBR, Hs90)	5
14	007900817	AS568-008 (NBR, Hs70)	3

COM-3/5

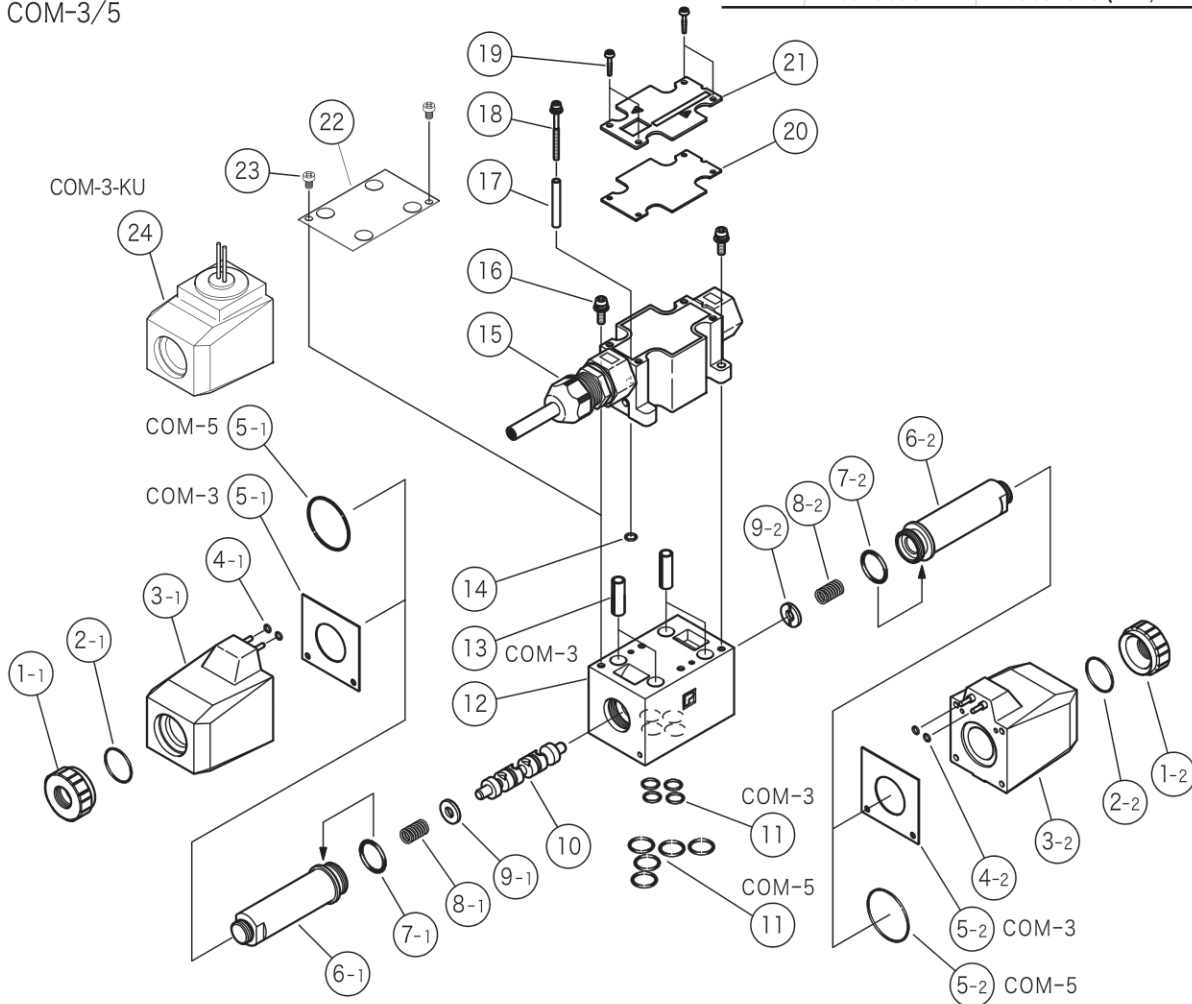

Construction

COM-52

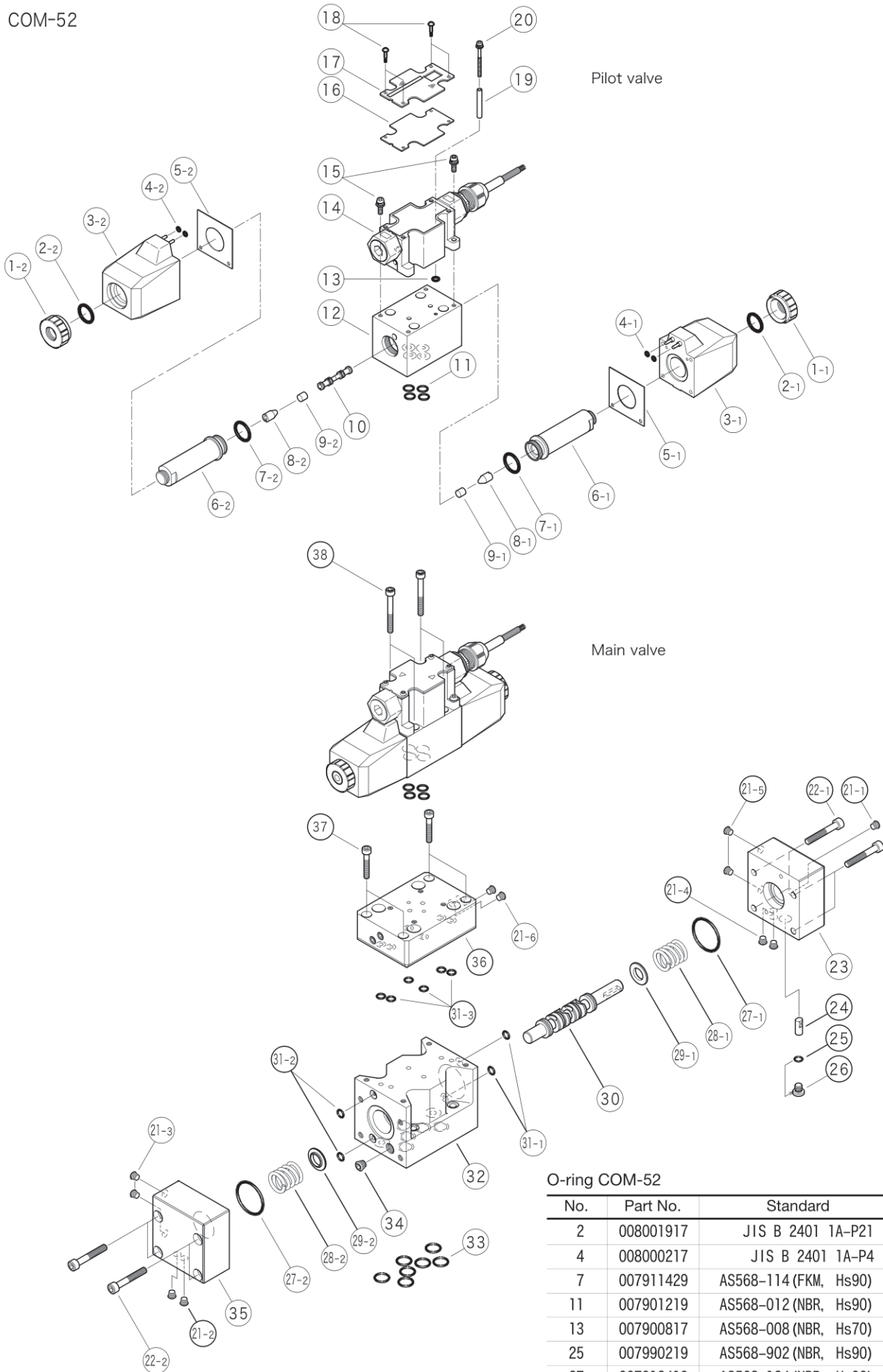

Pilot valve

Main valve

O-ring COM-52

No.	Part No.	Standard	Qty
2	008001917	JIS B 2401 1A-P21	2
4	008000217	JIS B 2401 1A-P4	4
7	007911429	AS568-114 (FKM, Hs90)	2
11	007901219	AS568-012 (NBR, Hs90)	4
13	007900817	AS568-008 (NBR, Hs70)	1
25	007990219	AS568-902 (NBR, Hs90)	1
27	007912419	AS568-124 (NBR, Hs90)	2
31	007901019	AS568-010 (NBR, Hs90)	10
33	007901419	AS568-014 (NBR, Hs90)	7

Construction

COM-7

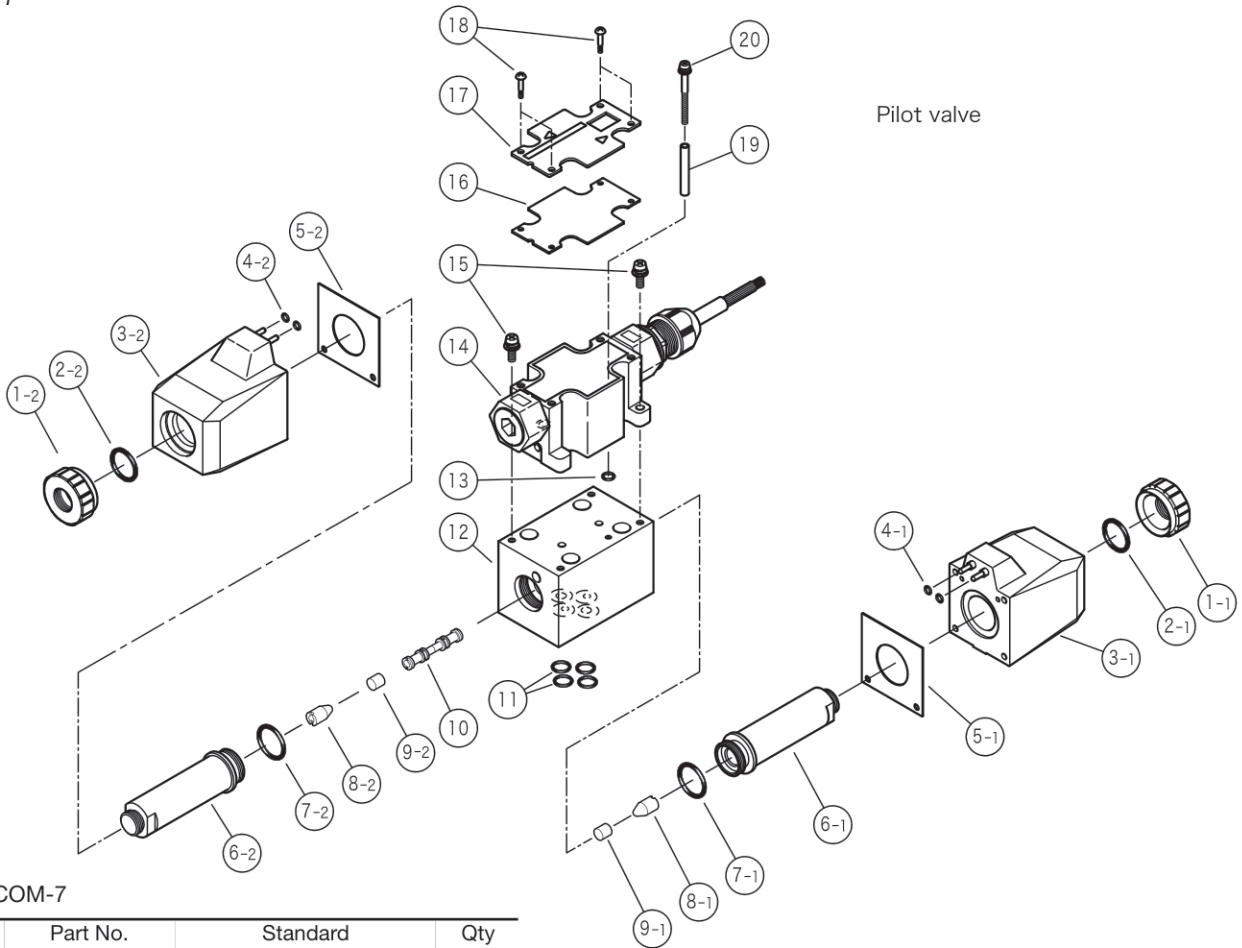

Pilot valve

Main valve

O-ring COM-7

No.	Part No.	Standard	Qty
2	008001917	JIS B 2401 1A-P21	2
4	008000217	JIS B 2401 1A-P4	4
7	007911429	AS568-114 (FKM, Hs90)	2
11	007901219	AS568-012 (NBR, Hs90)	4
13	007900817	AS568-008 (NBR, Hs70)	1
24	007990219	AS568-902 (NBR, Hs90)	1
27	007911019	AS568-110 (NBR, Hs90)	2
28	007912319	AS568-123 (NBR, Hs90)	2
32	008000619	JIS B 2401 1B-P8	2
33	007901317	AS568-013 (NBR, Hs70)	2
34	007911817	AS568-118 (NBR, Hs70)	4

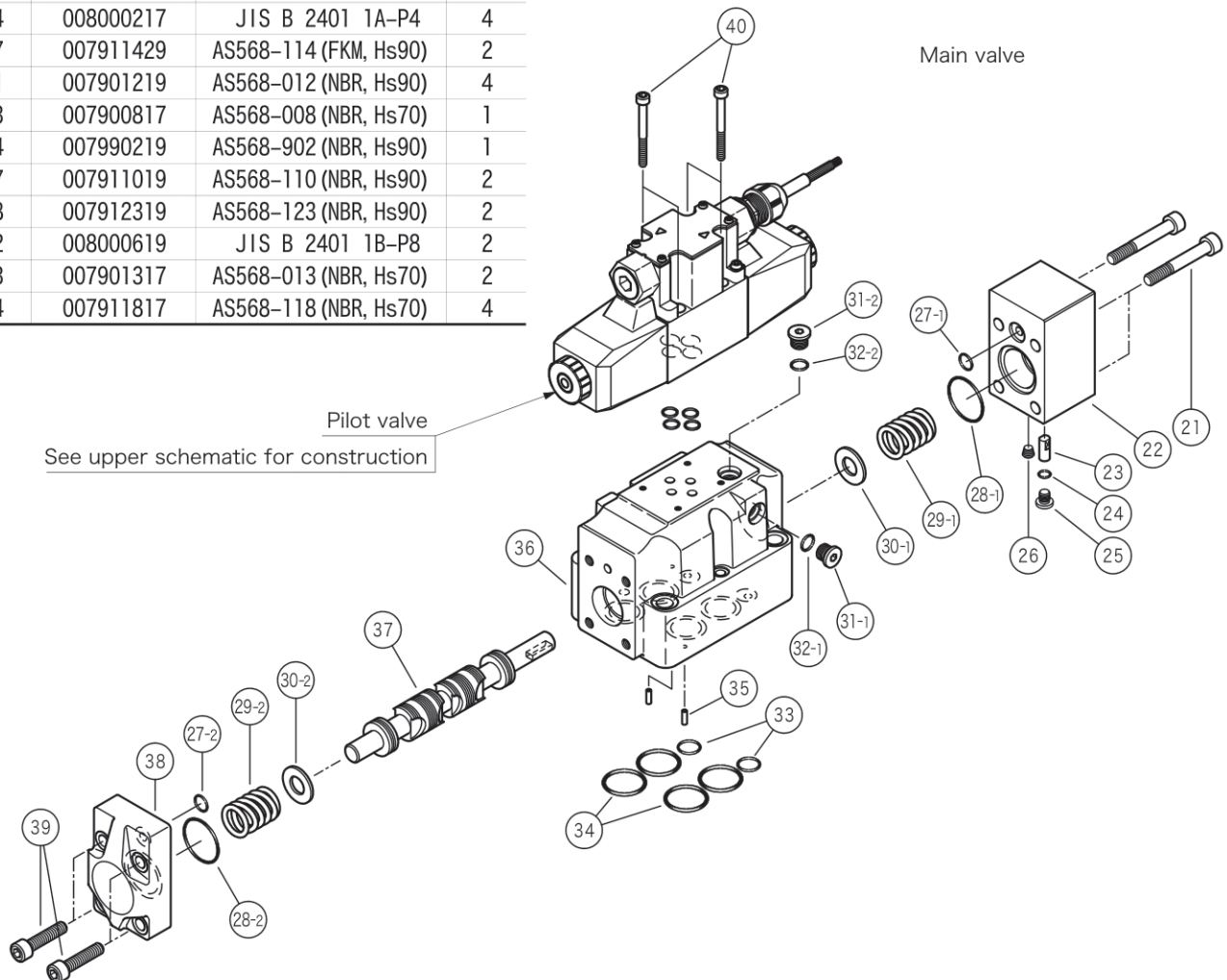

Pilot valve
See upper schematic for construction

Construction

COM-8

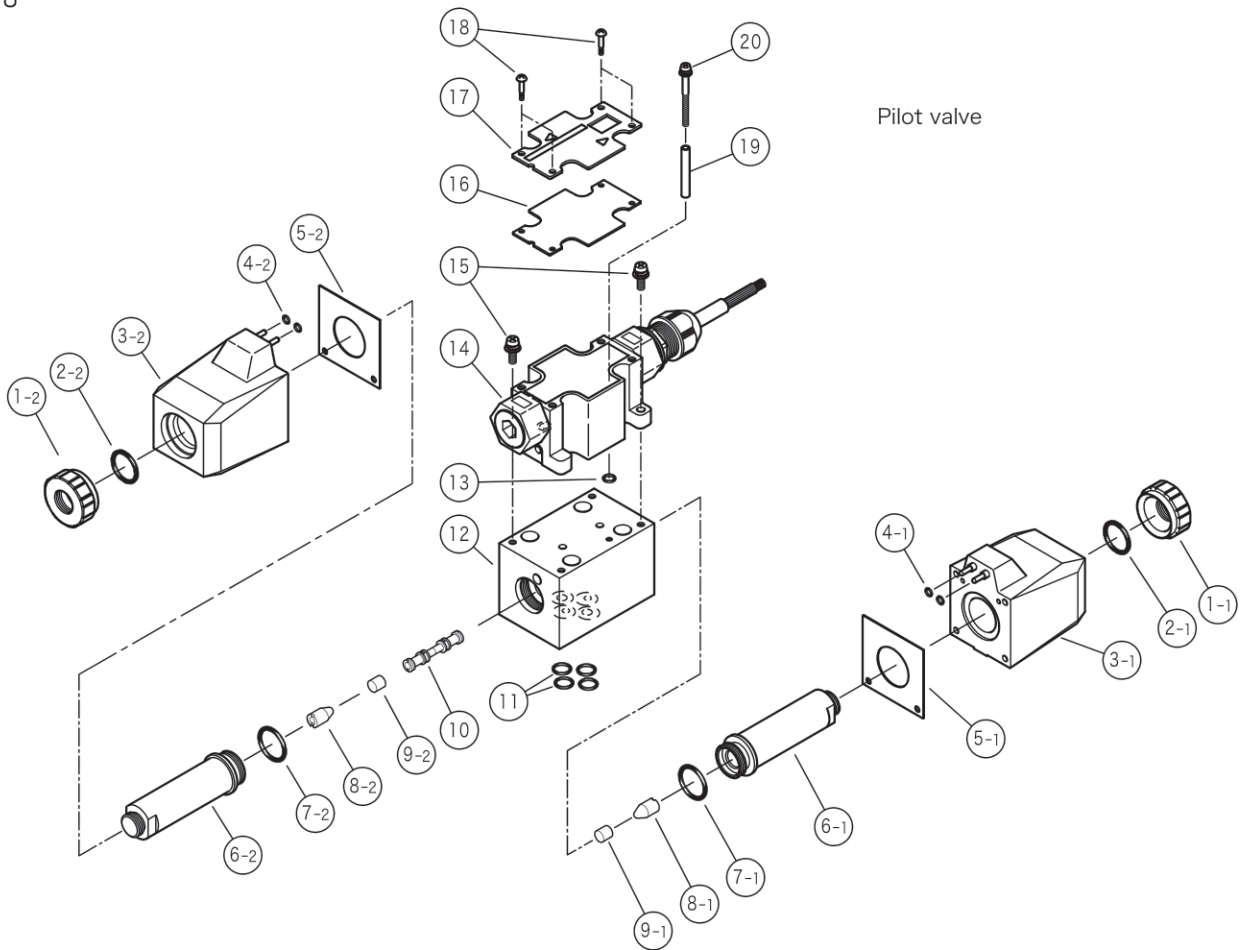

O-ring COM-8

No.	Part No.	Standard	Qty
2	008001917	JIS B 2401 1A-P21	2
4	008000217	JIS B 2401 1A-P4	4
7	007911429	AS568-114 (FKM, Hs90)	2
11	007901219	AS568-012 (NBR, Hs90)	4
13	007900817	AS568-008 (NBR, Hs70)	1
24	007990219	AS568-902 (NBR, Hs90)	1
28	007922417	AS568-224 (NBR, Hs70)	2
33	007921017	AS568-210 (NBR, Hs70)	2
34	007921517	AS568-215 (NBR, Hs70)	4

