

HPX Series

High Sensitivity over a Long Scanning Distance of 800mm (Thru Scan Model), Easy-to-Use Functions/Structure, and High Reliability.

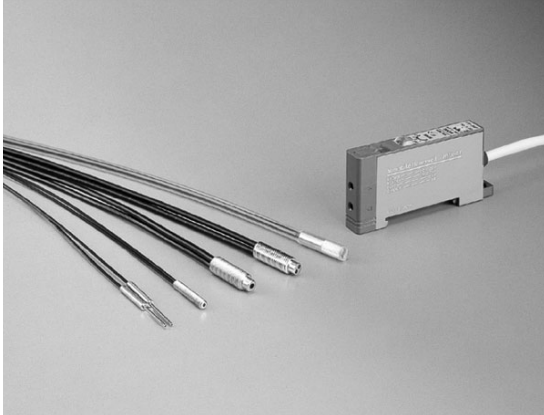

- Quick response (50μs) plus mark detection.
- Self-diagnostic LEDs plus self-diagnostic output.
- Fine-tuning of sensitivity using multi-turn potentiometer with indicator.

AMPLIFIER UNIT ORDER GUIDE

Model	Shape	Supply voltage	Outout mode	Operation mode	Sensitivity adjustment	Stability indication	Self-diagnostic indication	Self-diagnostic output	Timer function	Catalog listing
High sensitivity		10 to 30Vdc	NPN open collector	Light ON/ Light ON, selectable	<input type="radio"/>	<input type="radio"/>	<input type="radio"/>	<input type="radio"/>	<input type="radio"/>	HPX-H1
			PNP open collector		<input type="radio"/>	<input type="radio"/>	<input type="radio"/>	<input type="radio"/>	<input type="radio"/>	HPX-H2
Low hysteresis			NPN open collector		<input type="radio"/>	<input type="radio"/>	<input type="radio"/>	<input type="radio"/>	<input type="radio"/>	HPX-A1
			PNP open collector		<input type="radio"/>	<input type="radio"/>	<input type="radio"/>	<input type="radio"/>	<input type="radio"/>	HPX-A2
Fast detection			NPN open collector		<input type="radio"/>	<input type="radio"/>	<input type="radio"/>	<input type="radio"/>	<input type="radio"/>	HPX-F1
			PNP open collector		<input type="radio"/>	<input type="radio"/>	<input type="radio"/>	<input type="radio"/>	<input type="radio"/>	HPX-F2



AMPLIFIER UNIT SPECIFICATIONS

Model	High sensitivity	Low hysteresis	Fast response
Catalog listing	HPX-H□	HPX-A□	HPX-F□
Supply voltage	10 to 30Vdc (Ripple 10% max.)		
Current consumption	Max. 35mA		
Operating mode	Light operated/Dark operated, switch selectable		
Output form	NPN or PNP transistor open collector		
Control output	Output switching current: Max. 100mA (resistive load), output dielectric strength: Max. 30V, residual voltage: Max. 1V (at 100mA switching current), with output short-circuit protection circuit		
Self-diagnostic output	Output switching current: Max. 50mA (resistive load), output dielectric strength: Max. 30V, residual voltage: Max. 1V (at 50mA switching current), with output short-circuit protection circuit		
Response time	Max. 500 μ s for operation and recovery	Max. 50 μ s for operation, Max. 70 μ s for reset	
Sensitivity adjustment	3-turn potentiometer with indicator		
Light Emitter	Red LED		
Indicator	Light-operated (LO) indicator: Red (ON during LO), Stability indicator: Green (ON during stable LO or DO (dark-operated): blinking during self-diagnostics)		
Timer function	OFF delay 40ms/instantaneous switch selectable		
Ambient light immunity	Incandescent Lamp: Max. 5,000lx, Sun light: Max. 20,000lx		
Operating temperature range	-20 to +60°C (If gang mounted, max. operating temperature is 50°C)		
Storage temperature range	-40 to +70°C		
Humidity range	35 to 85%RH (non-condensing)		
Insulation resistance	Min. 20M Ω (500Vdc megger)		
Dielectric strength	1,000Vac 50/60Hz for 1 min. between case and all electrically live metals		
Vibration	10 to 55Hz, 1.5mm peak-to-peak amplitude, 2 hours each in X, Y, and Z directions		
Shock	500m/s ² repeated 3 times in X, Y, and Z directions		
Wiring method	Pre-leaded		
Weight	About 55g (body only, with 2 m cable)		
Others	Equipped with a reverse connection protection circuit and power on/off malfunction prevention circuit (about 100ms)		

FIBER UNIT AND AMPLIFIER COMBINATIONS

Thru scan

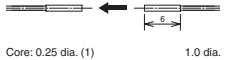
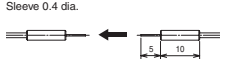
Group	Appearance	Amp	Scanning distance (mm)	Features	Cable length (cuttable)	Bend radius	Catalog listing
Long distance	<p>Core: 1.4 dia. (1) M4</p>	HPX-H HPX-A HPX-F		Long scanning distance	Cut to length 2m	R20	HPF-T001
	<p>Core: 1.4 dia. (1) 3 dia.</p>						HPF-T002
Standard	<p>Core: 1 dia. (1) M4</p>	HPX-H HPX-A HPX-F		Standard	Cut to length 2m	R20	HPF-T003
	<p>Core: 1 dia. (1) 3 dia.</p>						HPF-T004
	<p>Core: 1 dia. (1) M4</p>						HPF-T005
	<p>Core: 1 dia. (1) 3 dia.</p>			HPF-T006			
	<p>Core: 1 dia. (1) M4</p>			HPF-T005			
	<p>Core: 1 dia. (1) 3 dia.</p>			HPF-T006			
Ultra bend - tolerant	<p>Core: 0.5 dia. (1) M3</p>	HPX-H HPX-A HPX-F		Static installation, flexible, and small diameter	Cut to length 2m	R1	HPF-T024
	<p>Core: 1 dia. (1) M4</p>						HPF-T025
	<p>Core: 1 dia. (1) 3 dia.</p>			HPF-T031			
	<p>Sleeve 1 dia. 2.5 dia.</p>			HPF-T026			
Space saving	<p>Core: 1 dia. (1) M4</p>	HPX-H HPX-A HPX-F		Elbow	Cut to length 2m	R20	HPF-T010
	<p>Core: 0.5 dia. (1)</p>						HPF-T028
	<p>Core: 1 dia. (1)</p>			HPF-T028LF			
Side view	<p>Sleeve 1 dia. 2.5 dia.</p>	HPX-H HPX-A HPX-F		Small diameter sleeve	Cut to length 2m	R15	HPF-T007
	<p>Sleeve 0.88 dia. 2.5 dia.</p>						HPF-T037
	<p>Sleeve 3 dia. 35 dia.</p>			HPF-T042			
Small diameter	<p>Core: 0.25 dia. (1) 3 dia.</p>	HPX-H HPX-A HPX-F		Fine diameter	Cut to length 2m	R15	HPF-T015

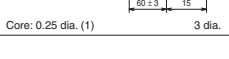
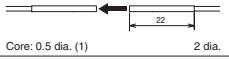
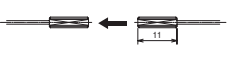
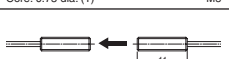
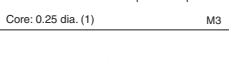
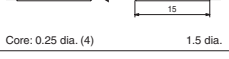
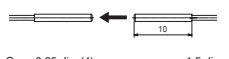
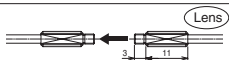
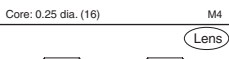
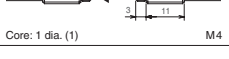
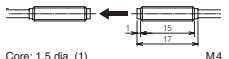
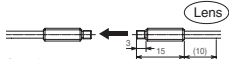
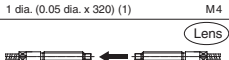
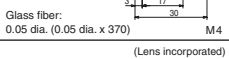
Group	Appearance	Amp	Scanning distance (mm)	Features	Cable length (cuttable)	Bend radius	Catalog listing
Small diameter		HPX-H 12 HPX-A 6 HPX-F 2		Fine diameter	Connector 0.5m	R15	HPF-T038
		HPX-H 6 HPX-A 3 HPX-F -		Fine diameter sleeve			HPF-T039
		HPX-H 12 HPX-A 6 HPX-F 2		Fine diameter sleeve	HPF-T040		
		HPX-H 100 HPX-A 50 HPX-F 20		Small diameter	Cut to length 2m		HPF-T043
		HPX-H 220 HPX-A 110 HPX-F 45		Small diameter and long scanning distance	HPF-T044		
Elastic				Elastic small diameter	Cut to length 2m	R4	HPF-T008
		HPX-H 100 HPX-A 40 HPX-F 20					HPF-T009
							HPF-T046
		HPX-H 265 HPX-A 130 HPX-F 50					Elastic standard diameter
Heat resistant		HPX-H 250 HPX-A 120 HPX-F 50		To 105°C	Cut to length 2m	R25	HPF-T012
		HPX-H 400 HPX-A 200 HPX-F 80		To 150°C			R35
		HPX-H 200 HPX-A 100 HPX-F 40		To 200°C	Connector 1m	R15	HPF-T018
		HPX-H 250 HPX-A 120 HPX-F 50		Heat and cold resistant from -60°C to +350°C	Connector 2m	R25	HPF-T014
Narrow beam		HPX-H 1,500 HPX-A 750 HPX-F 300		Parallel beam top view	Cut to length 2m	R20	HPF-T019
		HPX-H 1,600 HPX-A 800 HPX-F 320		Parallel beam side view			HPF-T020
		HPX-H 1,200 HPX-A 600 HPX-F 240		Narrow beam top view			R15
Mapping		HPX-H 350 HPX-A 175 HPX-F 70		Narrow beam -1.5'+1.5' max. side view	Cut to length 2m	R5	HPF-T030

Group	Appearance	Amp	Scanning distance (mm)	Features	Cable length (cuttable)	Bend radius	Catalog listing
Coaxial	<p>Lens Core: 0.25 dia. (emitter core dia.)(1) Core: 0.25 dia. (receiver core dia.)(6) M3</p>	HPX-H 25 HPX-A 13 HPX-F 5		Coaxial	Connector 0.5m	R4	HPF-D034
	<p>Lens Core: 0.5 dia. (emitter core dia.)(1) Core: 0.25 dia. (receiver core dia.)(9) M3</p>	HPX-H 50 HPX-A 25 HPX-F 10			Cut to length 2m	R15	HPF-D035
	<p>Lens Core: 0.5 dia. (emitter core dia.)(1) Core: 0.25 dia. (receiver core dia.)(9) M4</p>	HPX-H 40 HPX-A 20 HPX-F 8	Small diameter coaxial				HPF-D038
	<p>Sleeve 2 dia. Core: 0.5 dia. (emitter core dia.)(1) Core: 0.25 dia. (receiver core dia.)(9) 3 dia. M4</p>	HPX-H 40 HPX-A 20 HPX-F 8					HPF-D042
Side view	<p>Sleeve 2 dia. Core: 0.5 dia. (2) 3 dia. M3</p>	HPX-H 15 HPX-A 8 HPX-F 3		Small diameter sleeve	Cut to length 2m	R15	HPF-D011
	<p>Sleeve 2 dia. Core: 0.5 dia. (2) 2.8 dia. M3</p>	HPX-H 50 HPX-A 32 HPX-F 12		Small diameter short sleeve			HPF-D041
	<p>Sleeve 2 dia. Core: 0.5 dia. (2) 6 dia. M3</p>	HPX-H 50 HPX-A 32 HPX-F 12		Standard diameter		R20	HPF-D043
Elastic	<p>Core: 0.25 dia. (emitter core dia.)(16) Core: 0.25 dia. (receiver core dia.)(16) M6</p>	HPX-H 100 HPX-A 50 HPX-F 20		Standard	Cut to length 2m		HPF-D012
	<p>Core: 0.25 dia. (emitter core dia.)(2) Core: 0.25 dia. (receiver core dia.)(2) 1.5 dia. M3</p>	HPX-H 8 HPX-A 4 HPX-F -		Small diameter sleeve	Connector 1m	R4	HPF-D036
	<p>Core: 0.25 dia. (emitter core dia.)(2) Core: 0.25 dia. (receiver core dia.)(2) M3</p>	HPX-H 8 HPX-A 4 HPX-F -		Small diameter	Cut to length 2m		HPF-D037
Heat resistant	<p>Core: 1 dia. (2) M6</p>	HPX-H 100 HPX-A 50 HPX-F 20		To 105°C	Cut to length 2m	R25	HPF-D013
	<p>Core: 1.5 dia. (2) M6</p>	HPX-H 150 HPX-A 80 HPX-F 30		To 150°C		R35	HPF-D022
	<p>Glass fiber: 1.4 dia. Sleeve 2.1 dia. M6</p>	HPX-H 50 HPX-A 50 HPX-F 20		To 200°C	Connector 1m	R15	HPF-D023
	<p>Glass fiber: 1.4 dia. M6</p>	HPX-H 50 HPX-A 50 HPX-F 20		Sleeve heat resistant to 200°C			HPF-D024
	<p>Glass fiber: 1.5 dia. M6</p>	HPX-H 90 HPX-A 30 HPX-F 18		Heat and cold resistant from -60°C to 350°C	Cut to length 2m	R25	HPF-D015
Parallel beam	<p>(Built-in lens) M5</p>	HPX-H 20 HPX-A 20 HPX-F 12		Parallel beam reflection	Cut to length 2m	R15	HPF-D025
Wide beam	<p>M5</p>	HPX-H 100 HPX-A 50 HPX-F 20		Array	Cut to length 2m	R4	HPF-D026
Limited reflection	<p>M5</p>	HPX-H 2.5 ± 0.5 HPX-A 2.5 ± 0.5 HPX-F -		Limited reflection	Cut to length 2m	R15	HPF-D028

EXTERNAL DIMENSIONS

(unit: mm)

● Amplifier unit

HPX-H, A, F (in common)

When mounted on bracket (attached)

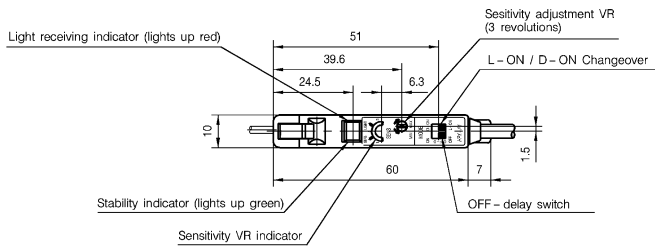

When mounted on DIN rail

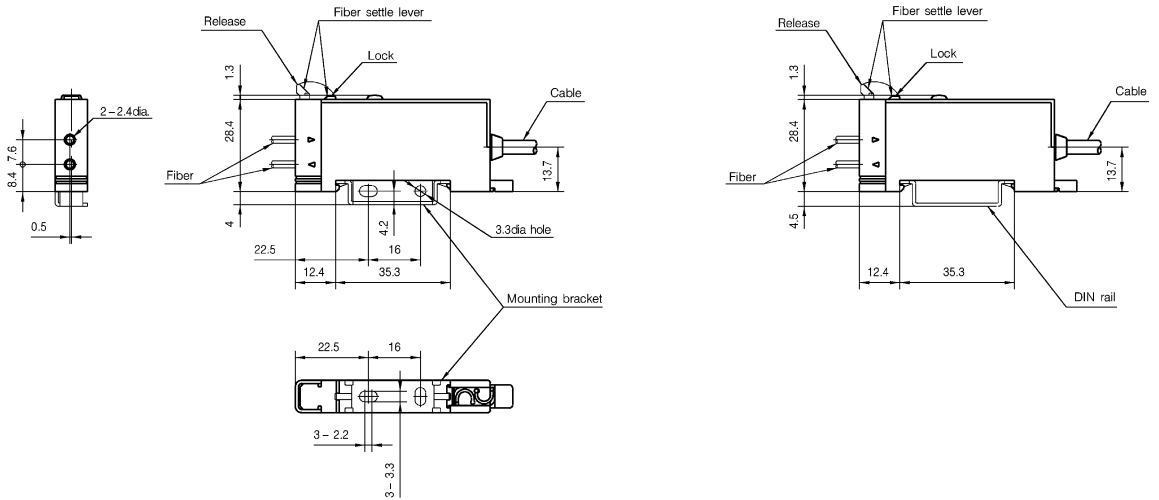

OUTPUT CIRCUIT DIAGRAM

• NPN output type

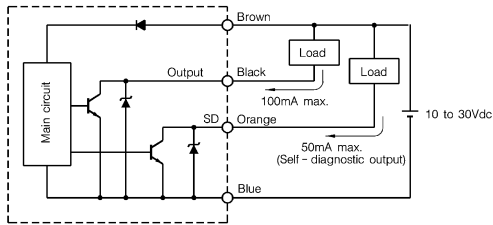

• PNP output type

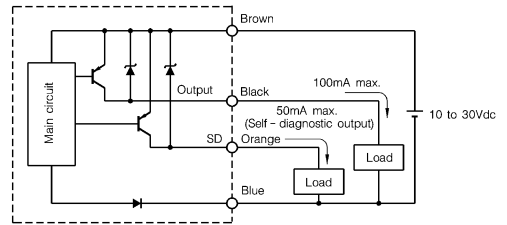

BASIC PRECAUTIONS

• Wiring

- Make sure you connect a photoelectric sensor to the power supply and load correctly.
- If a high-voltage or power cable exists near a photoelectric sensor lead, isolate the photoelectric sensor's lead or lay in another conduit to prevent surge and noise influence.
- Connect the lead securely to the connector using crimp terminal.
- Use a lead of at least 0.3mm² in cross-sectional area for extensions. The lead length should not be over 100m. Consider the influence of noise due to lead extension.
- If a switching power supply is used, ground its frame.
- If capacitive load is used, connect a current limiting resistor so as to limit the rush current to max. 100mA.

• Handling

- Do not swing a photoelectric sensor by its lead.
- Do not impact or damage the sensing head.
- Do not pull the lead of a photoelectric sensor with excessive force. The tensile strength is about 49N at 50cm from the end of the conduit.