

# Network Instrumentation Modules NX

## Digital Output Modules

### NX-DY1/DY2

#### Overview

Network Instrumentation Modules make optimal distributed configuration a reality. Distributed modules execute cooperative control using Ethernet connectivity. This instrumentation offers an excellent solution for productivity and energy conservation needs. You can select a type of output that depends on the module type.

- Transistor sink type
- Transistor source type

Logical arithmetic is available for each output. 32 groups of logical operations are provided. Since the SLP-NX Smart Loader Package can be connected via Ethernet, Network Instrumentation Modules can be set up and monitored over an Ethernet communications network.



#### Features

- Ethernet and RS-485 as standard features
- Up to 16 digital outputs per module
- Side connectors for reduced wiring
- Support for reduced wiring and distributed layout through daisy-chain connection
- 6 LED indicators (18 LEDs), and additional LEDs depending on the model, provide abundant status information
- 3-part structure for easy maintenance
- Linked modules can make use of input and output from
- 32 groups of logical operations are provided One operation group consists of four inputs and one output
- Time proportional output Assign the MV of another controller module to own output Approximation by Linearization Table
- One-shot pulse output
- Event output using instantaneous values Assign the ON/OFF status of another module to own event

#### Basic function block diagram of the NX-DY1/2

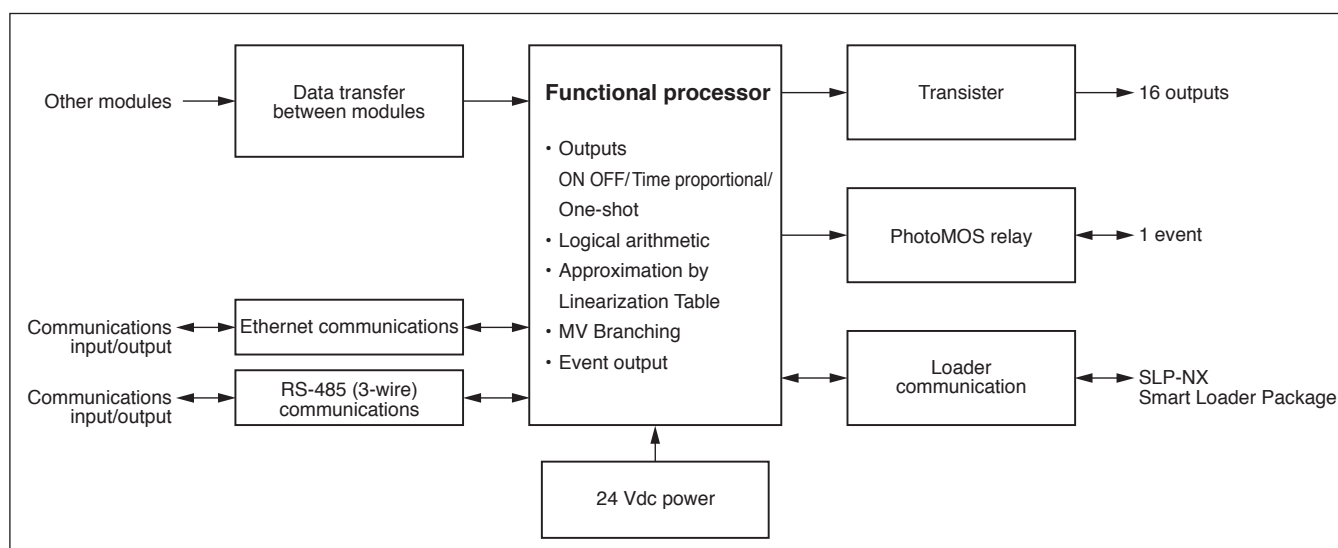

## Specifications

Model No.		NX-DY1	NX-DY2
<b>Wiring method</b>		Regular terminal block or screwless terminal block (available soon; ordered by model No.), screw terminals on base (for power and RS-485 communications)	
<b>Output</b>	<b>No. of outputs</b>	16	
	<b>Common terminal</b>	One for every eight channels	
	<b>Output type</b>	Transistor (sink type)	Transistor (source type)
	<b>Isolation between channels</b>	Channels 1–8 isolated from 9–16	
	<b>Recommended supply voltage</b>	24 Vdc	
	<b>Allowable supply voltage</b>	21.6–26.4 Vdc	
	<b>Allowable output current</b>	100 mAdc max./1 ch	
	<b>Off-state leakage current</b>	1.0 mA max.	
	<b>ON-state maximum voltage drop</b>	1.5 Vmax. (at 24 Vdc 0.1 A)	
	<b>Output refresh cycle</b>	50 ms	
<b>Digital output power supply voltage monitoring</b>	<b>Power interruption detecting voltage</b>	20.4 Vdc max.	
	<b>Detection terminals</b>	1–8 ch (VCC1)	
<b>Event output</b>	<b>No. of outputs</b>	1	
	<b>Rated contact voltage</b>	12–24 Vdc	
	<b>Applicable voltage range</b>	10–30 Vdc	
	<b>Allowable output current</b>	100 mAdc max.	
	<b>Output type</b>	Photo MOS relay output (non-voltage Form A contact)	
	<b>Polarity</b>	None	
	<b>Protection circuit</b>	Over current protection (self recover type)	
	<b>OFF-state leakage current</b>	100 uA max.	
	<b>ON-state maximum voltage drop</b>	2 V max. (at 24 Vdc 0.1 A)	
	<b>Output refresh cycle</b>	50 ms	
<b>Loader communications</b>	<b>Compatible loader</b>	SLP-NX-J70 or SLP-NX-J70PRO, SLP-NX-J71, SLP-NX-J71PRO	
	<b>Cable</b>	USB loader cable is included with the dedicated loader (SLP-NX-J70/SLP-NX-J70PRO)	
<b>RS-485 communications</b>	<b>Signal level</b>	Conforms to RS-485	
	<b>Network</b>	Multidrop (up to 31 units as slave stations for one host)	
	<b>Communication/synchronization method</b>	Half-duplex, start/stop synchronization	
	<b>Max. line length</b>	500 m	
	<b>No. of wires</b>	3-wire system	
	<b>Transmission speed</b>	4800, 9600, 19200, 38400, 57600, or 115200 bps	
	<b>Terminating resistor</b>	External (150 Ω 1/2 W min.)	
	<b>Data length</b>	7 or 8 bits	
	<b>Stop bit</b>	1 or 2 bits	
	<b>Parity bit</b>	Even, odd, or none	
	<b>Protocol</b>	Selectable from CPL, MODBUS/ASCII, and MODBUS/RTU	
<b>Ethernet communications (When using a communications adapter)</b>	<b>Transmission path type</b>	IEEE802.3u 100BASE-TX/IEEE 802.3u 100BASE-TX (With full duplex and auto MDI/MDI-X functions. The auto negotiation function must be activated on connected modules.)	
	<b>Connector</b>	RJ-45	
	<b>Cable</b>	UTP cable (4P) Cat 5e (straight) (ANSI/TIA/EIA-568-B both ends)	
	<b>Protocol</b>	CPL/TCP, MODBUS/TCP	

Model No.		NX-DY1	NX-DY2
General specifications	Standard conditions	Ambient temperature	23±2°C
		Ambient humidity	60 ±5 % RH (without condensation)
		Supply power	24 Vdc
		Vibration	0 m/s <sup>2</sup>
		Shock	0 m/s <sup>2</sup>
		Installation angle	Reference plane ±3°
	Operating conditions	Ambient temperature	0 to 50°C (under installed unit)
		Ambient humidity	10–90 % RH (without condensation)
		Allowable operating power voltage	21.6–26.4 Vdc
		Vibration	0 to 3.2 m/s <sup>2</sup> (10 to 150 Hz for 2 h each in x, y, and z directions)
		Shock	0–9.8 m/s <sup>2</sup>
		Installation angle	Reference plane ±3°
		Dust	0.3 mg/m <sup>3</sup> max.
		Corrosive gas	None
		Altitude	2000 m max.
		Pollution degree	2 (equivalent to a normal office environment)
	Transportation conditions	Ambient temperature	-20 to +70°C
		Ambient humidity	5–95 % RH (without condensation)
		Vibration	0–9.8 m/s <sup>2</sup> (10 to 150 Hz for 2 h each in x, y, and z directions)
		Shock	0–300 m/s <sup>2</sup> (vertically 3 times while on DIN rail)
		Package drop test	60 cm drop height (free drop on 1 corner, 3 edges, and 6 planes)
	others	Memory backup	Nonvolatile memory (EEPROM)
		EEPROM erase/write cycles	Up to 100,000
		Insulation resistance	500 Vdc, 20 MΩ or more (between power terminals 1 and 2, and between power terminals and isolated I/O terminals)
		Dielectric strength	500 Vac for 1 min (between power terminals 1 and 2, and between power terminals and isolated I/O terminals)
		Power consumption	4 W max. (under operating conditions)
		Operation after power-on	Warmup time is approx. 10 s (time until normal operation, under standard conditions)
		Inrush current	Max. 20 A (under operating conditions)
		External dimensions	30 × 100 × 100 mm (for details, see the external dimensions drawing)
		Case material	Modified PPO resin
		Case color	Black
		Mass	200 g max.
Mounting method		DIN rail	
Included accessories		Manual No. CP-UM-5564JE	
Terminal screw tightening torque		0.6 ±0.1 N·m	
Compliance		CE (EN61326-1) cUL (UL61010-1)	

## Model Number

Basic model No.	Type	Ring connection	Wiring method	Channels	Option	Addition	Description	
NX-							Network Instrumentation module	
	DY1						Digital output (Transistor output sink type)	
	DY2						Digital output (Transistor output source type)	
		N					Non-ring connection	
		R					Ring connection	
			T				Screw terminal block	
			S				Screwless terminal block	
					16		16 channels	
						0	None	
							0	None
							D	Inspection certificate
							T	Tropicalization treatment
							K	Anti-sulfide treatment
						B	Tropicalization treatment + Inspection certificate	
						L	Anti-sulfide treatment + Inspection certificate	

\*. Soon available

## External Dimensions

### External dimensions

- Regular terminal block model

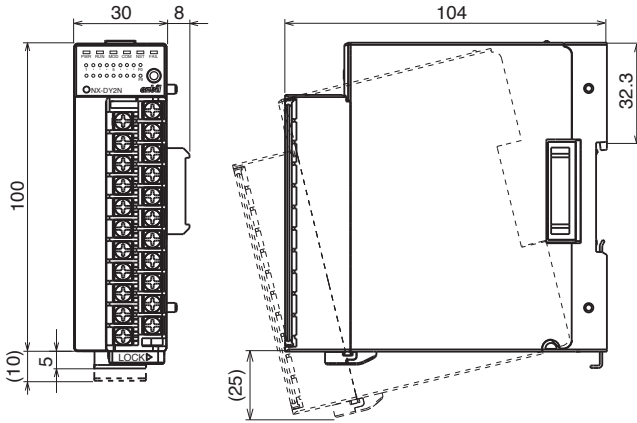

## Mounting

### Location

The minimum required clearances are shown below.

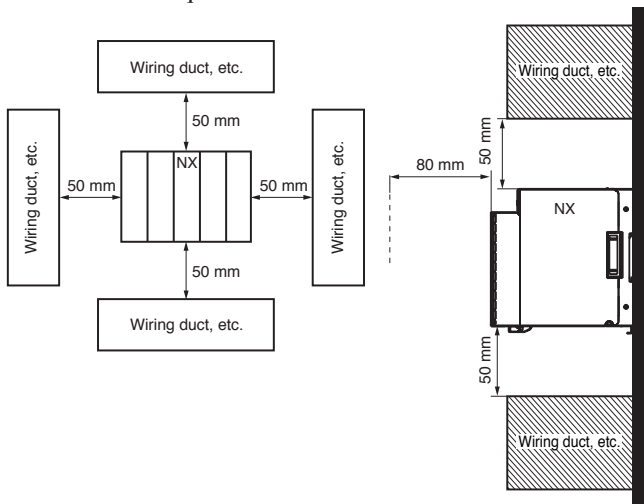

Do not install in a location having any of the following characteristics:

- High or low temperatures or high or low humidity outside of the specification range
- Sulfide gas or other corrosive gases
- Dust or oily smoke
- Direct sunlight, wind or rain
- Mechanical vibration or shock outside of the specification range
- Nearby high-voltage lines, welding machines or other sources of electrical noise
- Within 15 meters of a device with high-voltage ignition, such as a boiler
- Strong magnetic fields
- Flammable liquid or gas

### Terminal block mounting and removal

#### Handling Precautions

- Do not remove the terminal block other than for work, such as:
  - When wiring before installing the unit
  - During maintenance

#### Removal method

- Slide the lock lever of the terminal block to the left to unlock the terminal block.
- Pull the bottom of the terminal block out towards you.

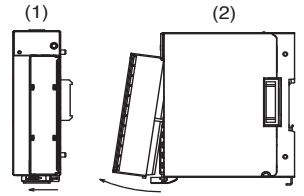

#### Mounting method

- Tilt the terminal block and insert the upper part of the terminal block into the groove in the case.
- Install by pushing in the lower side of the terminal block.
- Slide the lock lever of the terminal block to the right to lock the terminal block.

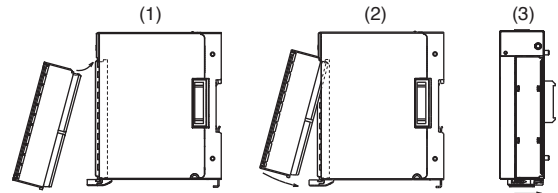

### Module connection

Connect this module to other modules using the connectors on the left and right sides of the base. Connect modules together before installing them on the DIN rail. Connecting the modules connects the power and communication of each module, reducing the amount of wiring that is required. With RS-485 communication, the module on the right side can be disconnected using the RS-485 cutoff switch on the base.

### Mounting method

Use this unit after securing it to a DIN rail. After mounting the DIN rail, pull open the locking tab an adequate amount and then attach the base to the rail. Next, push in the DIN rail locking tab upwards until it clicks into place.

#### Handling Precautions

- Mount the unit so that it is vertical with the DIN rail locking tab at the bottom.
- Link this unit before installing it on the DIN rail.

### Attaching the main unit to the base

#### Handling Precautions

- Use the base and main unit from the same package together as a pair.
- First attach the hook at the bottom of the main unit to the base. Not doing so might cause damage.

- Attach the hook at the bottom of the main unit to the base.
- Insert the upper part of the main unit until the lever clicks into place.

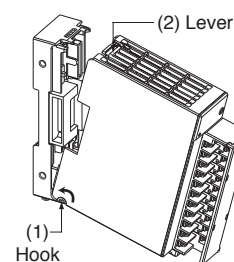

To remove, press the lever on the top and pull the unit towards you.

# Names and Functions of Parts

## ■ Main unit

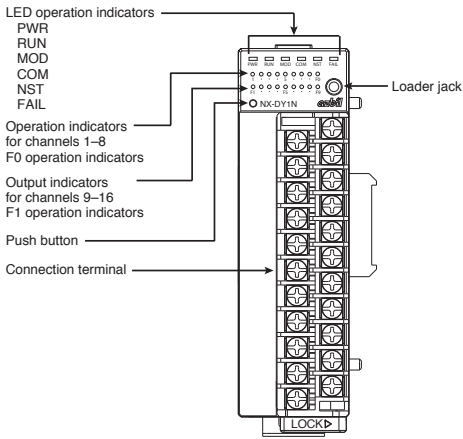

## ■ Base

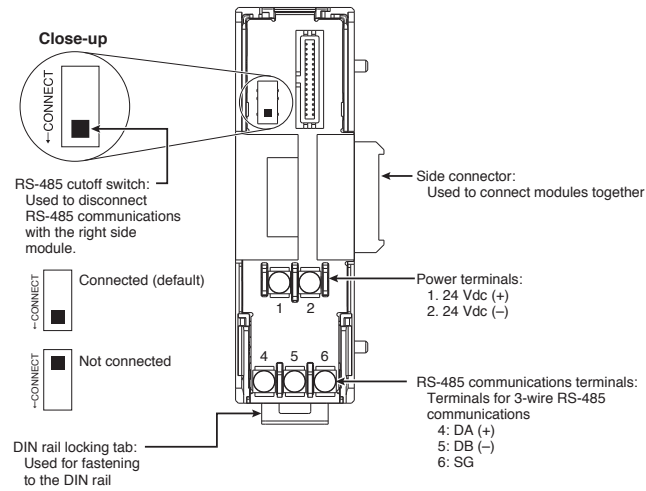

# Terminal Wiring Diagram

## ■ Wiring diagram

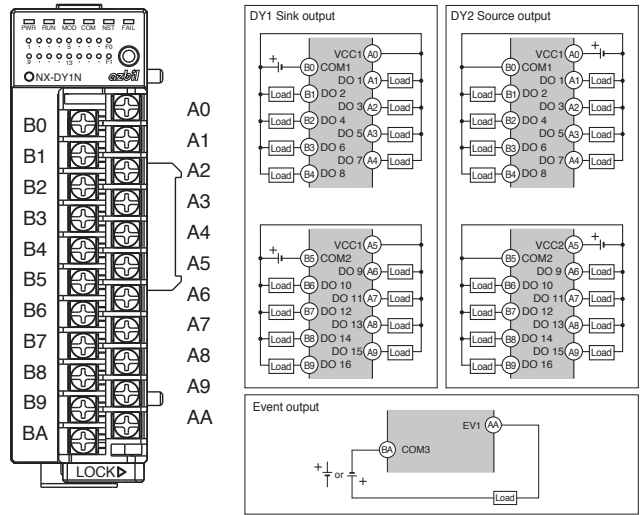

## ■ Wiring precautions

- Make sure that the wiring follows regulations for indoor wiring and technical standards for electrical equipment.
- To avoid damage caused by lightning, do not run wiring outdoors.
- When connecting wires to the power terminals, use crimp terminals with insulating sleeves.
- Before wiring the unit, verify the device's model No. and terminal Nos. written on the wiring diagram on the side of the main unit.
- Use M3 crimp terminal lugs for wiring to regular (screw) terminal blocks.
- Make sure that no crimp terminal lugs touch adjacent terminals.
- Leave a distance of at least 60 cm between I/O wires and communications wires or power wires. Also, do not pass such wires through the same conduit or wiring duct.
- When connecting the unit to another device in parallel, check its connection requirements carefully before instrumentation.
- To ensure stability, the unit is designed so that after the power is turned ON, it will not operate for about 10 seconds.
- After wiring, check that there are no wiring mistakes before turning the power ON.

## ■ Power connections

Connect the power terminals as shown below.

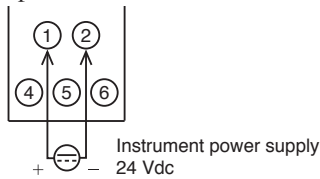

### ! Handling Precautions

- Electrical power is transferred between connected modules.
- Supply power to any one of the connected modules.
- Use a power source that has ample capacity for the total power consumption of the connected modules.

## ■ RS-485 communication connections

Connect CPL and MODBUS (RS-485 communication) as shown below.

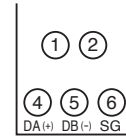

### ! Handling Precautions

- Attach a 0.5 W or greater terminating resistor of  $150 \Omega \pm 5 \%$  at each end of the communications lines. If a device does not allow terminating resistor to be placed in the same line, follow the instructions for that device.
- Be sure to connect the SG terminals together. Failure to do so might cause unstable communications.
- Use twisted pair cable for communication wiring.

## ■ I/O isolation

The solid lines in the diagram below indicate isolation from the rest of the circuit.

Power supply (including side connector)*1	Digital output channels 1–8
Logic circuits Loader jack RS-485 Ethernet communications through side connector*1 Displays (led, switch, etc.)	Digital output channels 9–16
Ring communication through side connector*1	Event output 1

\*1. Power, side-connector ring communications, and RS-485/side-connector Ethernet communications are isolated from each other connector.

Please read the "Terms and Conditions" from the following URL before ordering or use:

<http://www.azbil.com/products/bi/order.html>

*Specifications are subject to change without notice.*

The logo for Azbil Corporation, featuring the word "azbil" in a bold, lowercase, red sans-serif font.

**Azbil Corporation**  
Advanced Automation Company

1-12-2 Kawana, Fujisawa  
Kanagawa 251-8522 Japan  
URL: <http://www.azbil.com/>

1st Edition: Issued in Apr. 2012

*No part of this publication may be reproduced or duplicated without the prior written permission of Azbil Corporation.*