

Pressure Reducing Valves / Pressure Reducing and Check Valves

Pressure reducing valves are used to set the pressure of a hydraulic circuit below that of the main circuit. In addition, operation under remote control is possible by using the remote control port. Pressure reducing and check valves have check valves, which allow a free flow from the secondary side to the primary.

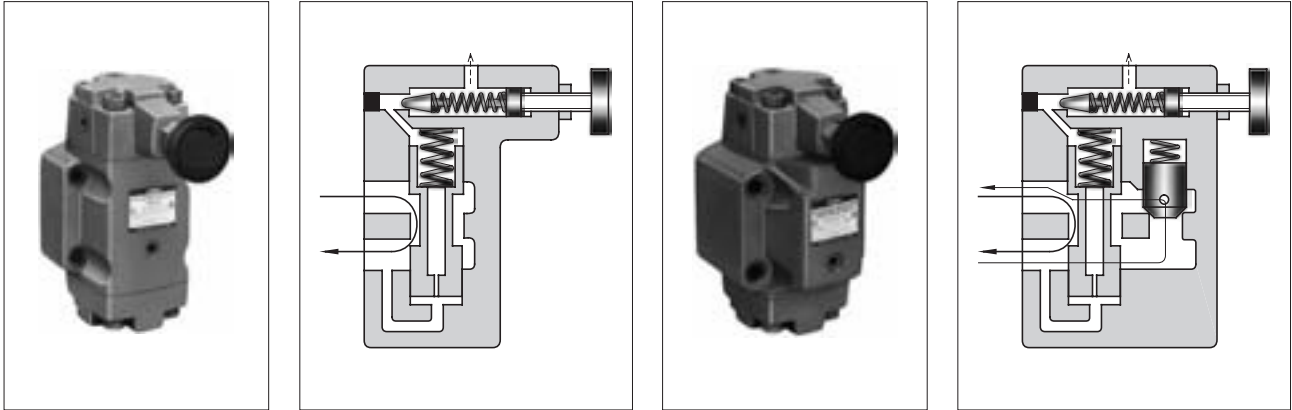

Specifications

Valve Name	Model Numbers		Max. Operating Pressure MPa (PSI)	Max. Flow ^{★1}		Drain Flow ^{★2} L/min (U.S.GPM)	Approx. Mass kg (lbs.)	
	Threaded Connection	Sub-plate Mounting		Setting Pressure MPa (PSI)	Max. Flow L/min (U.S.GPM)		Threaded Connection	Sub-plate Mounting
Pressure Reducing Valve	RT-03-*-22*	RG-03-*-22*	21 (3050)	0.7 - 1.0 (102 - 145)	40 (10.6)	0.8 - 1.0 (.21 - .26)	4.3 (9.5)	4.5 (9.9)
				1.0 - 20.5 (145 - 2970)	50 (13.2)			
	RT-06-*-22*	RG-06-*-22*	21 (3050)	0.7 - 1.0 (102 - 145)	50 (13.2)	0.8 - 1.1 (.21 - .29)	6.9 (15.2)	6.8 (15.0)
				1.0 - 1.5 (145 - 220)	100 (26.4)			
				1.5 - 20.5 (220 - 2970)	125 (33.0)			
	RT-10-*-22*	RG-10-*-22*	21 (3050)	0.7 - 1.0 (102 - 145)	130 (34.3)	1.2 - 1.5 (.32 - .40)	12.0 (26.5)	11.0 (24.3)
				1.0 - 1.5 (145 - 220)	180 (47.6)			
				1.5 - 10.5 (220 - 1520)	220 (58.1)			
				10.5 - 20.5 (1520 - 2970)	250 (66.0)			
Pressure Reducing and Check Valve	RCT-03-*-22*	RCG-03-*-22*	21 (3050)	0.7 - 1.0 (102 - 145)	40 (10.6)	0.8 - 1.0 (.21 - .26)	4.8 (10.6)	5.4 (11.9)
				1.0 - 20.5 (145 - 2970)	50 (13.2)			
	RCT-06-*-22*	RCG-06-*-22*	21 (3050)	0.7 - 1.0 (102 - 145)	50 (13.2)	0.8 - 1.1 (.21 - .29)	7.8 (17.2)	8.1 (17.9)
				1.0 - 1.5 (145 - 220)	100 (26.4)			
				1.5 - 20.5 (220 - 2970)	125 (33.0)			
	RCT-10-*-22*	RCG-10-*-22*	21 (3050)	0.7 - 1.0 (102 - 145)	130 (34.3)	1.2 - 1.5 (.32 - .40)	13.8 (30.4)	13.8 (30.4)
				1.0 - 1.5 (145 - 220)	180 (47.6)			
				1.5 - 10.5 (220 - 1520)	220 (58.1)			
				10.5 - 20.5 (1520 - 2970)	250 (66.0)			

★1. The max. flow rates are those shown at the primary pressure at 21 MPa (3050 PSI).

★2. The drain flow rates are equal to pilot flow rates when differential pressure between primary and secondary pressure is at 20.5 MPa (2970 PSI).

Graphic Symbols

● RT / RG

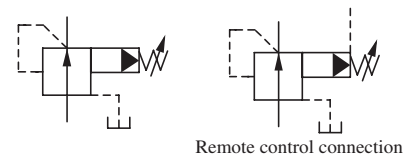

● RCT / RCG

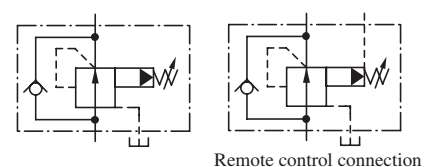

Yuken can offer flanged connection valves described below.

For details, contact us.

Model Numbers	Max. Operating Pressure MPa (PSI)	Max. Flow L/min (U.S.GPM)
RF/RCF-10-*-22*	21 (3050)	250 (66)
RF/RCF-16-*-20*		500 (132)

Model Number Designation

F-	R	T	-03	-B	-22	*
Special Seals	Series Number	Type of Mounting	Valve Size	Pres. Adj. Range MPa (PSI)	Design Number	Design Standards
F: Special Seals for Phosphate Ester Type Fluids (Omit if not required)	R: Pressure Reducing Valves	T: Threaded Connection	03	B: 0.7-7 (102-1020) C: 3.5-14 (510-2030) H: 7-20.5 (1020-2970)	22	None: Japanese Std. "JIS" 80: European Design Std. 90: N.American Design Std.
			06		22	
			10		22	
		G: Sub-plate Mounting	03		22	
			06		22	
			10		22	
	RC: Pressure Reducing and Check Valves	T: Threaded Connection	03	B: 0.7-7 (102-1020) C: 3.5-14 (510-2030) H: 7-20.5 (1020-2970)	22	None: Japanese Std. "JIS" 80: European Design Std. 90: N.American Design Std.
			06		22	
			10		22	
		G: Sub-plate Mounting	03		22	
			06		22	
			10		22	

Attachment

Mounting bolts

Valve Model Numbers	Socket Head Cap Screw		Qty.
	Japanese Std. "JIS" and European Design Std.	N. American Design Std.	
RG-03	M10 × 50 Lg.	3/8-16 UNC × 2 Lg.	4
RG-06	M10 × 50 Lg.	3/8-16 UNC × 2 Lg.	4
RG-10	M10 × 50 Lg.	3/8-16 UNC × 2 Lg.	6
RCG-03	M10 × 70 Lg.	3/8-16 UNC × 2-3/4 Lg.	4
RCG-06	M10 × 80 Lg.	3/8-16 UNC × 3-1/4 Lg.	4
RCG-10	M10 × 90 Lg.	3/8-16 UNC × 3-1/2 Lg.	6

Sub-plate

Valve Model Numbers	Japanese Standard "JIS"		European Design Standard		N. American Design Standard		Approx. Mass kg (lbs.)
	Sub-plate Model Numbers	Thread Size	Sub-plate Model Numbers	Thread Size	Sub-plate Model Numbers	Thread Size	
RG RCG ⁻⁰³	HGM-03-20	Rc 3/8	HGM-03-2080	3/8 BSP.F	HGM-03-2090	3/8 NPT	1.6 (3.5)
	HGM-03X-20	Rc 1/2	HGM-03X-2080	1/2 BSP.F	HGM-03X-2090	1/2 NPT	
RG RCG ⁻⁰⁶	HGM-06-20	Rc 3/4	HGM-06-2080	3/4 BSP.F	HGM-06-2090	3/4 NPT	2.4 (5.3)
	HGM-06X-20	Rc 1	HGM-06X-2080	1 BSP.F	HGM-06X-2090	1 NPT	3.0 (6.6)
RG RCG ⁻¹⁰	HGM-10-20	Rc 1-1/4	HGM-10-2080	1-1/4 BSP.F	HGM-10-2090	1-1/4 NPT	4.8 (10.6)
	HGM-10X-20	Rc 1-1/2	HGM-10X-2080	1-1/2 BSP.F	HGM-10X-2090	1-1/2 NPT	5.7 (12.6)

- Sub-plates are available. Specify the sub-plate model number from the table above. When sub-plates are not used, the mounting surface should have a good machined finish.
- The sub-plates are the same as those for H type pressure control valves. With the reducing and check valve, the sub-plate is used in a position 180° turned (upside down) from the normal position. When mounting the sub-plate, be sure to bring the valve locating pin to the sub-plate pin hole. For dimensions, see [page 244 to 246](#).

Instructions

- To adjust the pressure, loosen the lock nut and turn the pressure adjustment handle slowly clockwise for higher pressures and anti-clockwise for lower pressures. After adjustments, do not forget to tighten the lock nut.
- Connect the drain port directly to the reservoir in which case the pressure at the drain port should be kept at a low back pressure close to the atmospheric pressure.
- In case of "Threaded Connections", there are two threaded connection type primary pressure ports. They can be connected each other in-line; one as an inlet and the other as an outlet or the valve can be used by plugging one of the pressure ports.

RT-03-*-22/2280/2290

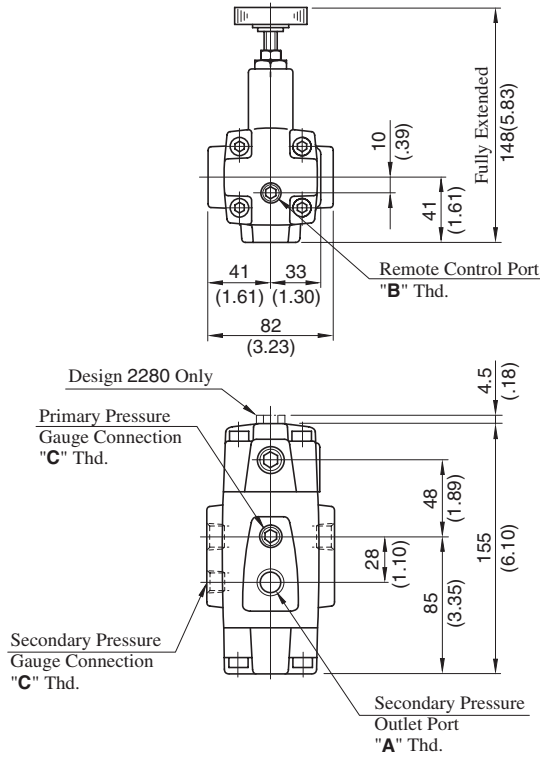

Model Numbers	Thread Size		
	"A" Thd.	"B" Thd.	"C" Thd.
RT-03-*-22	Rc 3/8	Rc 1/4	Rc 1/4
RT-03-*-2280	3/8 BSP.F	1/4 BSP.F	1/4 BSP.Tr
RT-03-*-2290	3/8 NPT	1/4 NPT	1/4 NPT

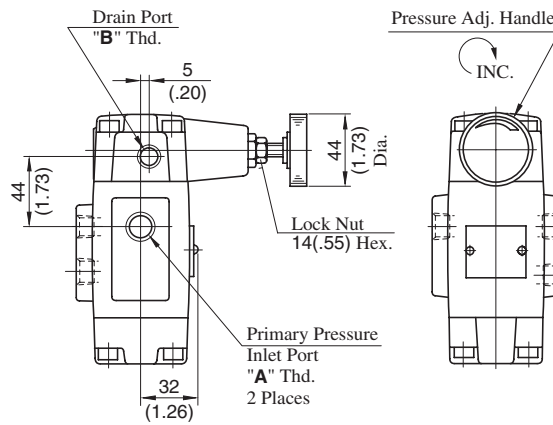

DIMENSIONS IN MILLIMETRES (INCHES)

RT-10⁰⁶-*-22/2280/2290

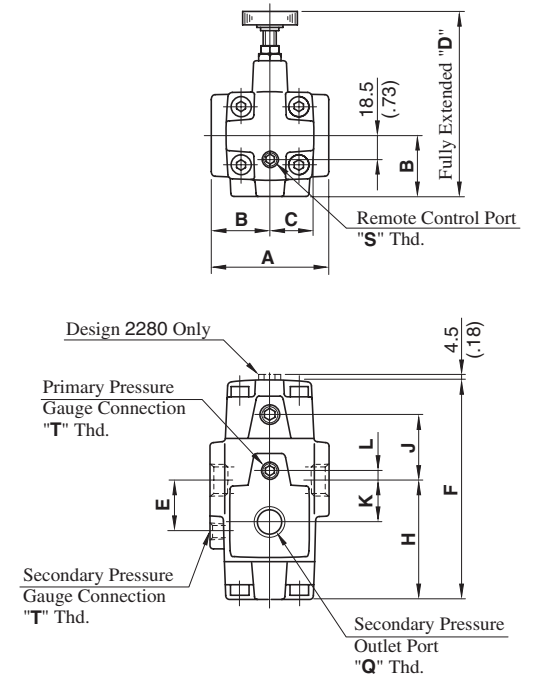

Model Numbers	Thread Size		
	"Q" Thd.	"S" Thd.	"T" Thd.
RT-06-*-22	Rc 3/4	Rc 1/4	Rc 1/4
RT-06-*-2280	3/4 BSP.F	1/4 BSP.F	1/4 BSP.Tr
RT-06-*-2290	3/4 NPT	1/4 NPT	1/4 NPT
RT-10-*-22	Rc 1-1/4	Rc 1/4	Rc 1/4
RT-10-*-2280	1-1/4 BSP.F	1/4 BSP.F	1/4 BSP.Tr
RT-10-*-2290	1-1/4 NPT	1/4 NPT	1/4 NPT

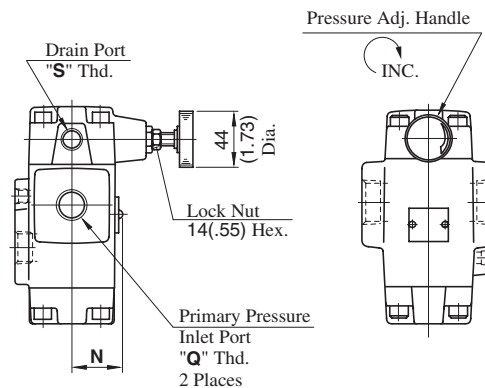

Model Numbers	Dimensions - mm (Inches)										
	A	B	C	D	E	F	H	J	K	L	N
RT-06	96 (3.78)	48 (1.89)	36.5 (1.44)	149 (5.87)	42 (1.65)	179 (7.05)	97.5 (3.84)	53.5 (2.11)	33 (1.30)	9 (.35)	39 (1.54)
RT-10	132 (5.20)	66 (2.60)	43 (1.69)	167 (6.57)	52 (2.05)	216 (8.50)	124 (4.88)	64 (2.52)	40 (1.57)	12 (.47)	46 (1.81)

Pressure Reducing Valves / Pressure Reducing and Check Valves

RG-03/06-*-22/2280/2290

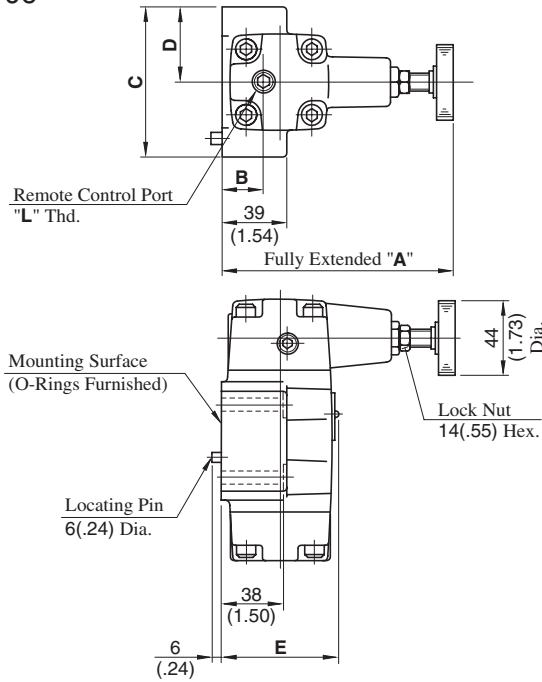

Model Numbers	Thread Size	
	"L" Thd.	"N" Thd.
RG-03/06-*-22	Rc 1/4	Rc 1/4
RG-03/06-*-2280	1/4 BSP.F	1/4 BSP.Tr
RG-03/06-*-2290	1/4 NPT	1/4 NPT

★ Port connection is not required for RG models but an O-ring should be furnished.

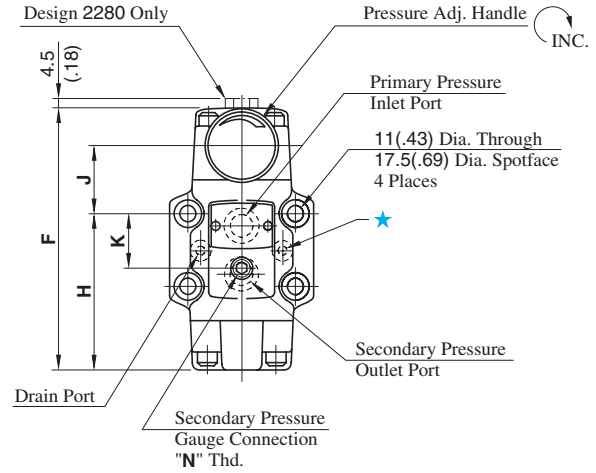

Model Numbers	Dimensions mm (Inches)								
	A	B	C	D	E	F	H	J	K
RG-03	142 (5.59)	25 (.98)	89 (3.50)	44.5 (1.75)	67 (2.64)	155.5 (6.12)	92.4 (3.64)	40.6 (1.60)	34.9 (1.37)
RG-06	141 (5.55)	21.5 (.85)	102 (4.02)	51 (2.01)	79 (3.11)	179 (7.05)	111 (4.37)	40 (1.57)	48 (1.89)

Note: For dimensions of the valve mounting surface see the dimensional drawing (page 244 & 245) of the sub-plate used together.

DIMENSIONS IN MILLIMETRES (INCHES)

RG-10-*-22/2280/2290

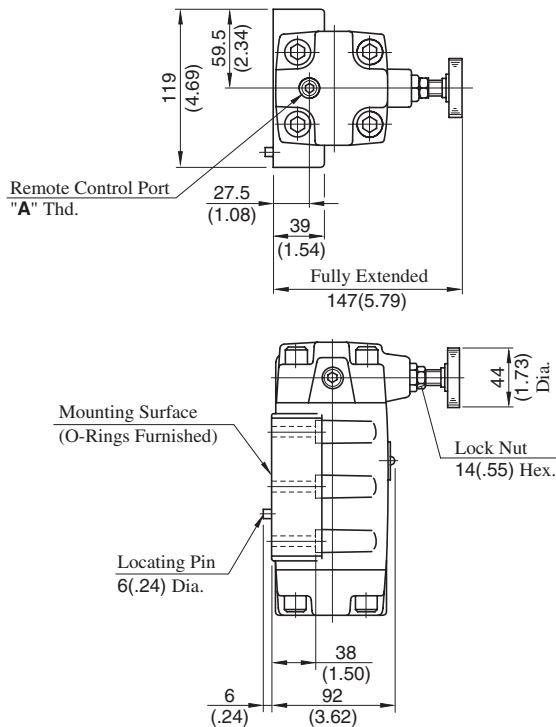

Model Numbers	Thread Size	
	"A" Thd.	"B" Thd.
RG-10-*-22	Rc 1/4	Rc 1/4
RG-10-*-2280	1/4 BSP.F	1/4 BSP.Tr
RG-10-*-2290	1/4 NPT	1/4 NPT

★ Port connection is not required for RG models but an O-ring should be furnished.

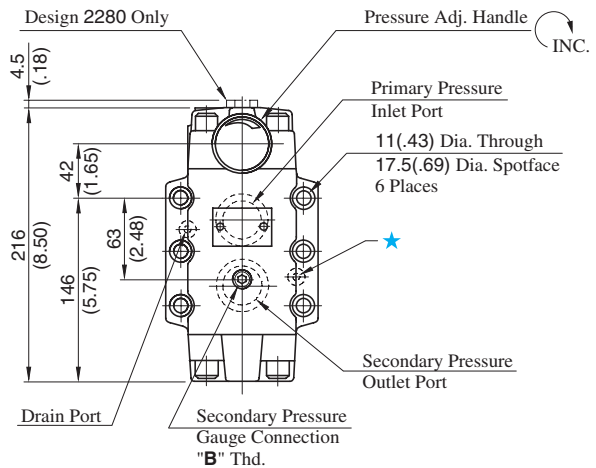

Note: For dimensions of the valve mounting surface see the dimensional drawing (page 246) of the sub-plate used together.

RCT-03-*-22/2280/2290

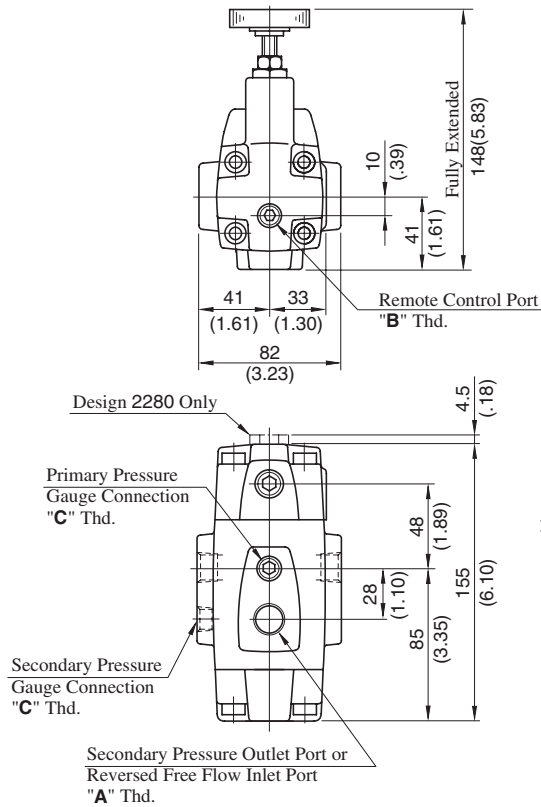

Model Numbers	Thread Size		
	"A" Thd.	"B" Thd.	"C" Thd.
RCT-03-*-22	Rc 3/8	Rc 1/4	Rc 1/4
RCT-03-*-2280	3/8 BSP.F	1/4 BSP.F	1/4 BSP.Tr
RCT-03-*-2290	3/8 NPT	1/4 NPT	1/4 NPT

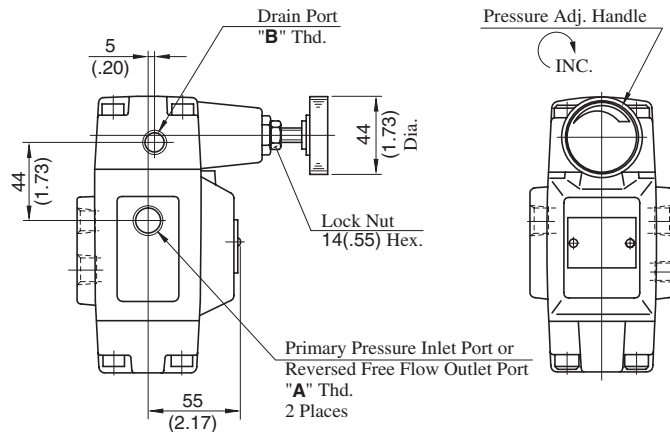

DIMENSIONS IN MILLIMETRES (INCHES)

RCT-06₁₀-*-22/2280/2290

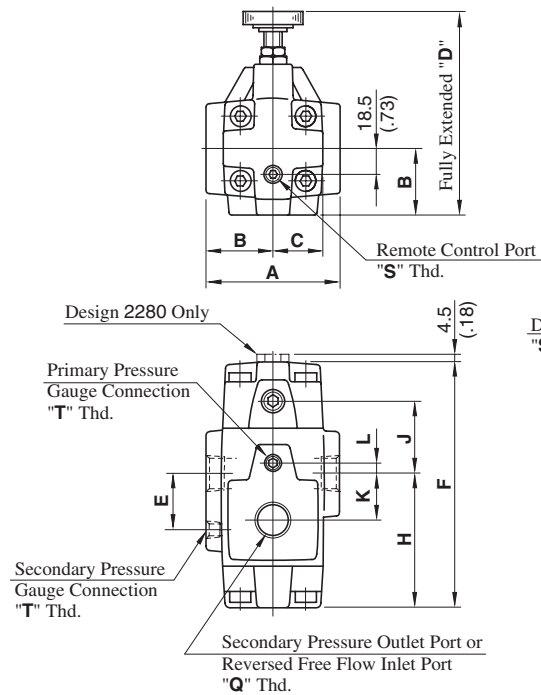

Model Numbers	Thread Size		
	"Q" Thd.	"S" Thd.	"T" Thd.
RCT-06-*-22	Rc 3/4	Rc 1/4	Rc 1/4
RCT-06-*-2280	3/4 BSP.F	1/4 BSP.F	1/4 BSP.Tr
RCT-06-*-2290	3/4 NPT	1/4 NPT	1/4 NPT
RCT-10-*-22	Rc 1-1/4	Rc 1/4	Rc 1/4
RCT-10-*-2280	1-1/4 BSP.F	1/4 BSP.F	1/4 BSP.Tr
RCT-10-*-2290	1-1/4 NPT	1/4 NPT	1/4 NPT

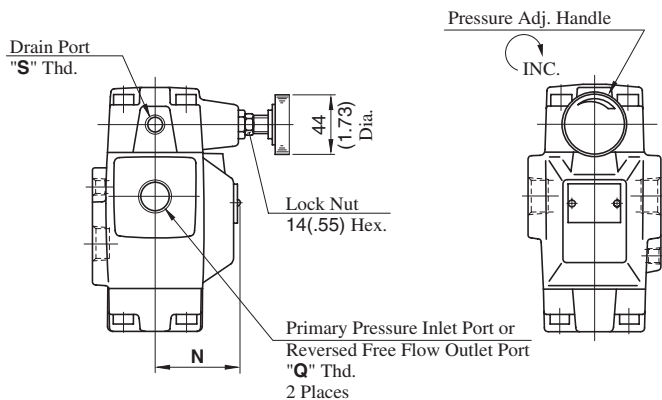

Model Numbers	Dimensions mm (Inches)										
	A	B	C	D	E	F	H	J	K	L	N
RCT-06	96 (3.78)	48 (1.89)	36.5 (1.44)	149 (5.87)	42 (1.65)	179 (7.05)	97.5 (3.84)	53.5 (2.11)	33 (1.30)	9 (.35)	68 (2.68)
RCT-10	132 (5.20)	66 (2.60)	43 (1.69)	167 (6.57)	52 (2.05)	216 (8.50)	124 (4.88)	64 (2.52)	40 (1.57)	12 (.47)	86 (3.39)

RCG-03-06-22/2280/2290

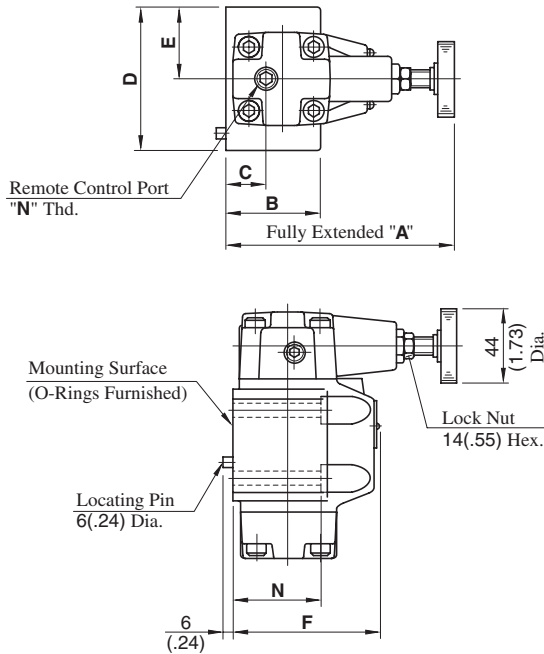

Model Numbers	Thread Size	
	"N" Thd.	"P" Thd.
RCG-03/06-22	Rc 1/4	Rc 1/4
RCG-03/06-2280	1/4 BSP.F	1/4 BSP.Tr
RCG-03/06-2290	1/4 NPT	1/4 NPT

★ Port connection is not required for RCG models but an O-ring should be furnished.

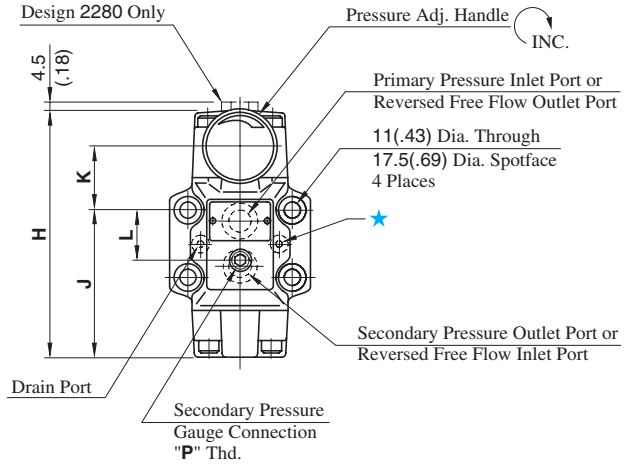

Model Numbers	Dimensions mm (Inches)										
	A	B	C	D	E	F	H	J	K	L	N
RCG-03	142 (5.59)	59 (2.32)	25 (.98)	89 (3.50)	44.5 (1.75)	90 (3.54)	155 (6.10)	92.4 (3.64)	40.6 (1.60)	34.9 (1.37)	58 (2.28)
RCG-06	141 (5.55)	69 (2.72)	21.5 (.85)	102 (4.02)	51 (2.01)	108 (4.25)	179 (7.05)	111 (4.37)	40 (1.57)	48 (1.89)	68 (2.68)

Note: For dimensions of the valve mounting surface see the dimensional drawing (page 244 & 245) of the sub-plate used together.

DIMENSIONS IN MILLIMETRES (INCHES)

RCG-10-22/2280/2290

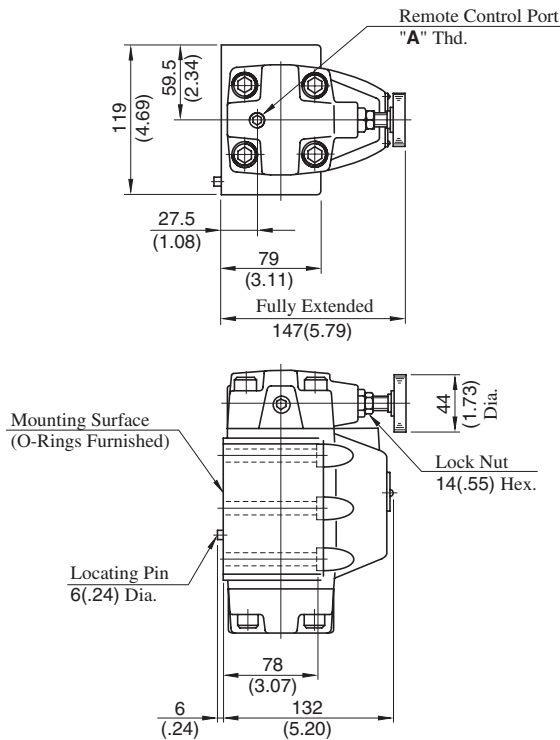

Model Numbers	Thread Size	
	"A" Thd.	"B" Thd.
RCG-10-22	Rc 1/4	Rc 1/4
RCG-10-2280	1/4 BSP.F	1/4 BSP.Tr
RCG-10-2290	1/4 NPT	1/4 NPT

★ Port connection is not required for RCG models but an O-ring should be furnished.

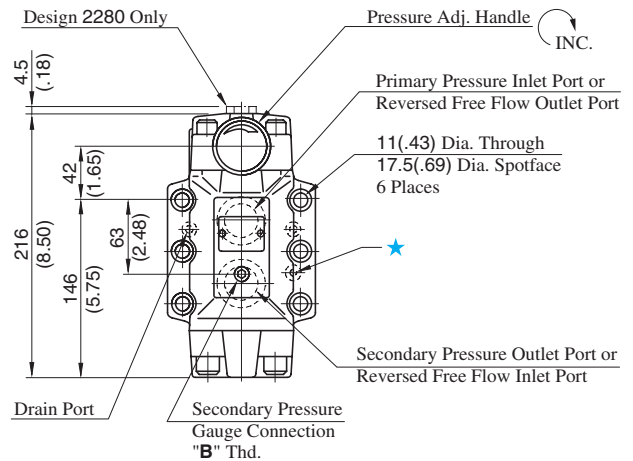

Note: For dimensions of the valve mounting surface see the dimensional drawing (page 246) of the sub-plate used together.

Pressure Drop for Reversed Free Flow

Hydraulic Fluid: Viscosity 35 mm²/s (164 SSU), Specific Gravity 0.850

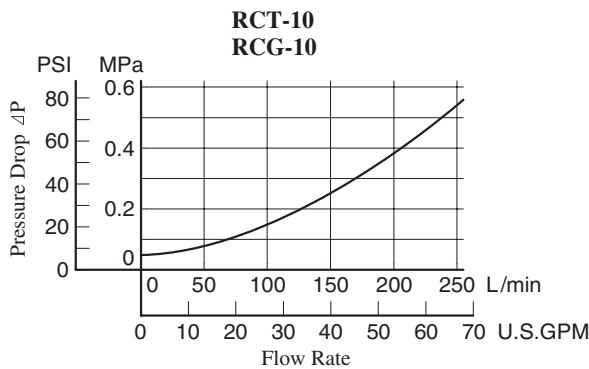
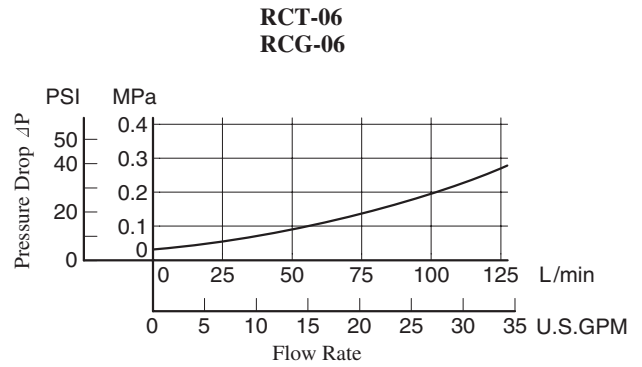
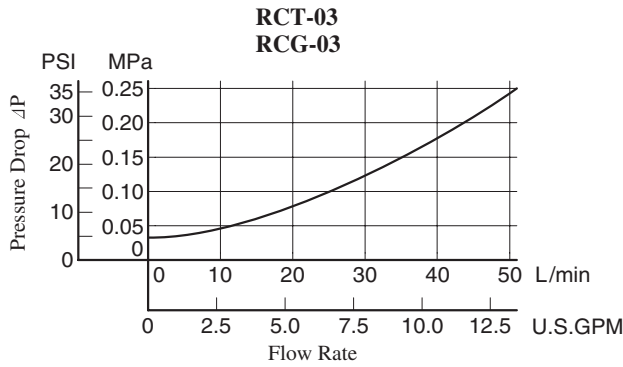

• For any other viscosity, multiply the factors in the table below.

Viscosity	mm ² /s	15	20	30	40	50	60	70	80	90	100
	SSU		77	98	141	186	232	278	324	371	417
Factor		0.81	0.87	0.96	1.03	1.09	1.14	1.19	1.23	1.27	1.30

• For any other specific gravity (G'), the pressure drop ($\Delta P'$) may be obtained from the formula below.

$$\Delta P' = \Delta P (G'/0.850)$$

Flow Rate vs. Secondary Pressure

Primary Pressure : 21 MPa (3050 PSI)
Hydraulic Fluid : Viscosity 35 mm²/s (164 SSU)

Pressure Adj. Range

----- : "B"
- - - - - : "C"
————— : "H"

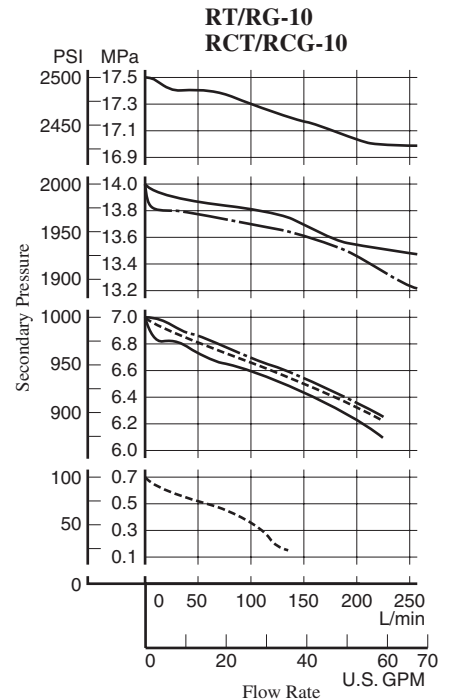
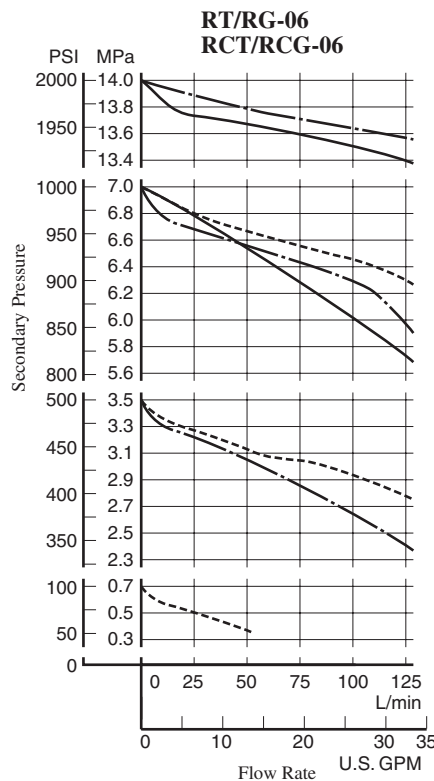
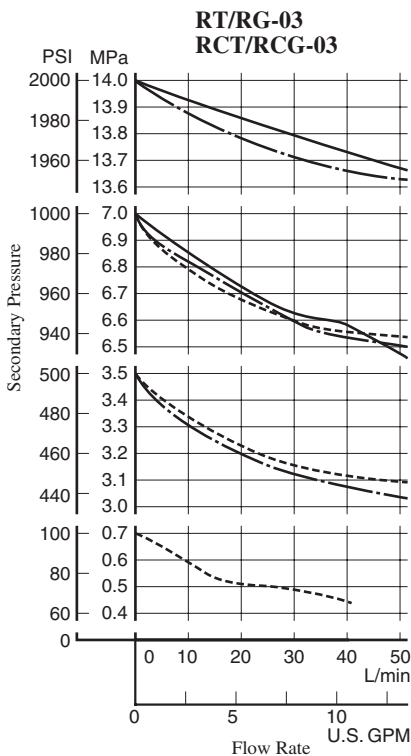

■ Spare Parts List

RT/RG-03-*-22/2280/2290
 RT/RG-06-*-22/2280/2290
 RT/RG-10-*-22/2280/2290

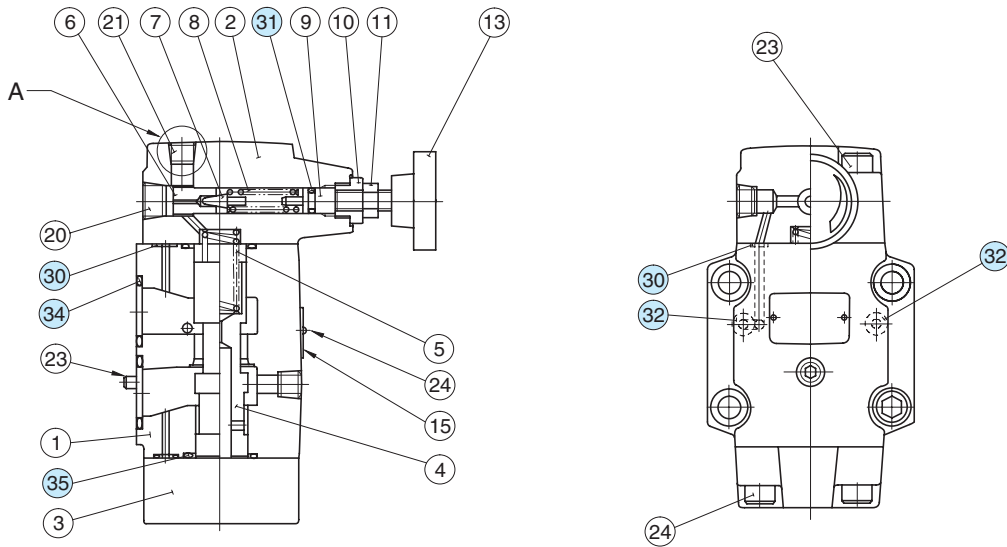

● List of Seals

Item	Name of Parts	Part Numbers			Quantity	
		RT RG -03	RT RG -06	RT RG -10	RT-*	RG-*
30	O-Ring	SO-NB-P6	SO-NB-P6	SO-NB-P6	4	4
31	O-Ring	SO-NA-P9	SO-NA-P9	SO-NA-P9	1	1
32	O-Ring	SO-NB-P9	SO-NB-P9	SO-NB-P9	—	2
34	O-Ring	SO-NB-P18	SO-NB-P28	SO-NB-P32	—	2
35	O-Ring	SO-NB-P22	SO-NB-P28	SO-NB-P36	2	2
37	Bonded Seal	SG-FB-1/4	SG-FB-1/4	SG-FB-1/4	1	1

Note: When ordering the seals, please specify the seal kit number from the table below.

● List of Seal Kits

Valve Model Numbers	Seal Kit Numbers
RT-03-*-22/2280/2290	KS-RT-03-22
RT-06-*-22/2280/2290	KS-RT-06-22
RT-10-*-22/2280/2290	KS-RT-10-22
RG-03-*-22/2280/2290	KS-RG-03-22
RG-06-*-22/2280/2290	KS-RG-06-22
RG-10-*-22/2280/2290	KS-RG-10-22

Note: No bonded seals are included in the seal kits.

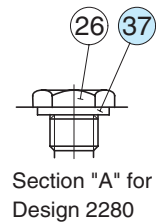

■ Spare Parts List

RCT/RCG-03-*-22/2280/2290
 RCT/RCG-06-*-22/2280/2290
 RCT/RCG-10-*-22/2280/2290

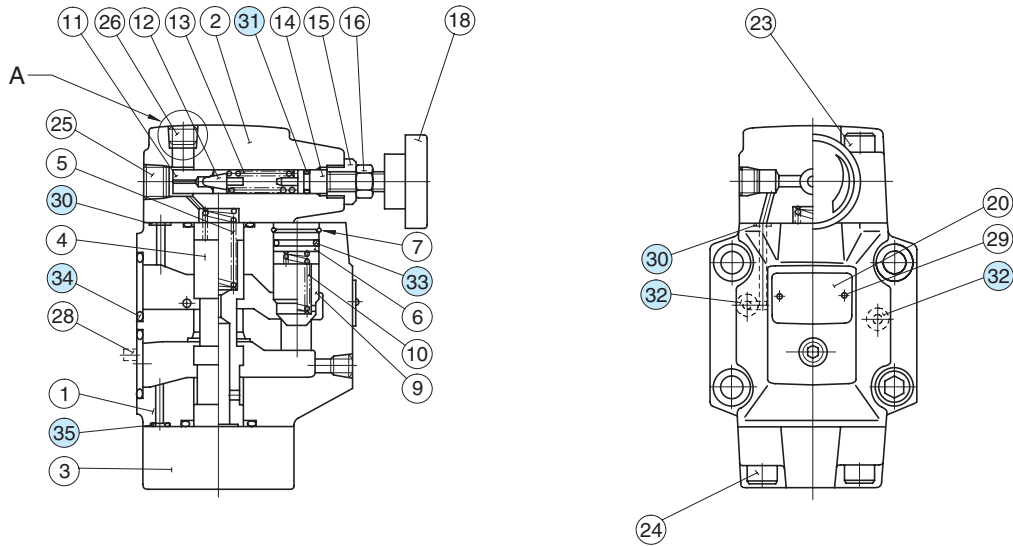

● List of Seals

Item	Name of Parts	Part Numbers			Quantity	
		RCT RCG-03	RCT RCG-06	RCT RCG-10	RCT-*	RCG-*
30	O-Ring	SO-NB-P6	SO-NB-P6	SO-NB-P6	4	4
31	O-Ring	SO-NA-P9	SO-NA-P9	SO-NA-P9	1	1
32	O-Ring	SO-NB-P9	SO-NB-P9	SO-NB-P9	—	2
33	O-Ring	SO-NB-P12	SO-NB-P18	SO-NB-P22A	1	1
34	O-Ring	SO-NB-P18	SO-NB-P28	SO-NB-P32	—	2
35	O-Ring	SO-NB-P22	SO-NB-P28	SO-NB-P36	2	2
37	Bonded Seal	SG-FB-1/4	SG-FB-1/4	SG-FB-1/4	1	1

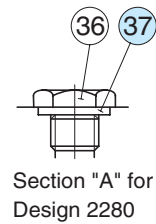

Note: When ordering the seals, please specify the seal kit number from the table below.

● List of Seal Kits

Valve Model Numbers	Seal Kit Numbers
RCT-03-*-22/2280/2290	KS-RCT-03-22
RCT-06-*-22/2280/2290	KS-RCT-06-22
RCT-10-*-22/2280/2290	KS-RCT-10-22
RCG-03-*-22/2280/2290	KS-RCG-03-22
RCG-06-*-22/2280/2290	KS-RCG-06-22
RCG-10-*-22/2280/2290	KS-RCG-10-22

Note: No bonded seals are included in the seal kits.